

**MEWN PERTHYNAS Â CHYFEIRIAD GAN OMBWDSMON GWASANAETHAU
CYHOEDDUS CYMRU I BWYLLGOR SAFONAU CYNGOR SIR YNYS MÔN YN
UNOL AG ADRAN 69 DEDDF LLYWODRAETH LEOL 2000**

**CWYN A WNAED YN ERBYN Y CYNGHORYDD JOHN FOULKES, CYNGHORAU
CYMUNED PENMYNYDD A STAR**

DATGANIAD TYST

Datganiad Dewi Francis Jones

Swydd: Rheolwr Datblygu Cynllunio, Cyngor Sir Ynys Môn

Rwy'n gwneud y Datganiad hwn o fy ngwybodaeth fy hun oni bai y nodir fel arall.

1.1 Gofynnwyd i mi baratoi datganiad ar ran y Gwasanaeth Cynllunio er mwyn cynorthwyo'r Pwyllgor Safonau gyda'r mater uchod. Yn benodol, rwy'n rhoi sylw i'r canlynol:

Effaith gynseiliol cais 41C124 ar geisiadau'r Cyngorydd Foulkes ei hun.

1.2 Dyma'r ceisiadau cynllunio perthnasol;

- Cais cynllunio cyfeirnod 41C124 – Cais llawn gan Mr Dafydd Jones i godi un tyrbín gwynt hyd at 44 m o uchder, gyda rotor o hyd at 56m ar ei draws, a hyd at 71m i flaen y llafn ynghyd â chodi gorsaf trawsnewidydd, adeilad cadw offer a thrac mynediad newydd a llecyn caled ar dir yn Ty Fry, Rhoscefnhir.
- Cais cynllunio cyfeirnod 41C66E – Cais llawn gan Mr John Foulkes i godi un tyrbín gwynt hyd at 50m i'r hwb, gyda rotor o hyd at 54m ar ei draws a hyd at 78m o uchder i flaen y llafn ynghyd ag isadeiledd cysylltiedig ar dir ym Marchynys, Penmynydd.
- Cais Cynllunio cyfeirnod 41C110B – Cais llawn i godi un tyrbín gwynt a fydd hyd at 78m o uchder i flaen y llafn ynghyd â lleoli isadeiledd cysylltiedig ar dir yn Tyn Buarth, Penmynydd.

1.3 Dyma statws cyfredol pob un o'r ceisiadau:

- Cafodd Cais Cynllunio rhif 41C124, sef cais "Ty Fry" ei dynnu'n ôl ar 26 Ionawr 2012 ond cafodd ei ailgyflwyno ar 19 Tachwedd 2012 dan gyfeirnod cynllunio 41C124B ac ar hyn o bryd, nid oes penderfyniad wedi ei wneud yn ei gylch.

**IN THE MATTER OF A REFERRAL BY THE PUBLIC SERVICES OMBUDSMAN
FOR WALES TO THE ISLE OF ANGLESEY COUNTY COUNCIL STANDARDS
COMMITTEE PURSUANT TO SECTION 69 OF THE LOCAL GOVERNMENT ACT
2000**

**COMPLAINT MADE AGAINST COUNCILLOR JOHN FOULKES OF THE
PENMYNYDD AND STAR COMMUNITY COUNCILS**

WITNESS STATEMENT

Statement of Dewi Francis Jones

**Occupation: Planning Development Manager, the Isle of Anglesey County
Council**

I make this Statement from my own knowledge and belief unless otherwise stated.

1.1 I have been asked to prepare a statement on behalf of the Planning Service in order to assist the Standards Committee in respect of the above matter. Specifically I deal with the following;

The precedent effect of application 41C124 on Councillor Foulkes' own applications.

1.2 The relevant planning applications are identified as being;

- Planning Application reference number 41C124 – A full application made by Mr Dafydd Jones for the erection of one wind turbine with a maximum height of up to 44m, rotor diameter of up to 56m and a maximum upright vertical tip height of up to 71m together with the erection of a transformer station, utility housing and new access track and hard-standing on land at Ty Fry, Rhoscefnhir.
- Planning Application reference number 41C66E – A full application made by Mr John Foulkes for the erection of one wind turbine with a maximum hub height of up to 50m, rotor diameter of up to 54m, and a maximum upright vertical tip height of up to 78m together with associated infrastructure on land at Marchynys, Penmynydd.
- Planning Application reference number 41C110B – A full application for the erection of one wind turbine with a maximum upright vertical tip height of up to

- Nid oes penderfyniad wedi ei wneud hyd yma ynghylch Cais Cynllunio cyfeirnod 41C66E, sef cais "Marchynys" oherwydd y disgwylir am ychwaneg o wybodaeth.
- Cafodd Cais Cynllunio cyfeirnod 41C110B, sef cais "Tyn Buarth" ei ddychwelyd heb benderfyniad i'r ymgeisydd ar 1 Medi 2012 oherwydd na chafodd gwybodaeth ei chyflwyno a oedd yn hanfodol ar gyfer gwneud penderfyniad ar y cais.

1.4 Mae copi o bob un o'r ceisiadau ynghlwm yn atodiadau 1, 2 a 3 ynghyd â chynllun yn nodi lleoliad y tri safle y mae wnelo'r ceisiadau â nhw yn atodiad 4.

2.0 Effaith gynseiliol cais 41C124 ar geisiadau'r Cynghorydd Foulkes ei hun

2.1 Rwyf wedi darllen Adroddiad yr Ombwdsmon a'r cyngor a gafwyd gan ei ymgynghorydd cynllunio annibynnol ynghylch a fedrid ystyried bod llwyddiant cais cynllunio am dyrbin gwynt yn yr ardal yn gosod cynsail ai peidio ar gyfer ceisiadau yn y dyfodol am dyrbinau gwynt yn yr ardal ac yn dylanwadu ar y fath geisiadau o bosib.

2.2 Roedd yr ymgynghorydd cynllunio yn canolbwyntio yn y lle cyntaf ar geisiadau "Tŷ Fry" a "Marchynys" a dywedodd ei fod o'r farn *"that the two sites and developments share sufficient common factors that a precedent would be established by the grant of planning permission on one of the sites"* er iddo dymheru hyn drwy fynd yn ei flaen i ddweud bod effaith cynsail o'r fath *"always tempered by other planning factors"*. Daeth yr ymgynghorydd cynllunio i'r casgliad fod cefnogaeth y Cynghorydd Foulkes i gais "Tŷ Fry" *"has some bearing on the prospects of the other"*.

2.5 Rwy'n cytuno gyda'r ymgynghorydd cynllunio y gall gosod cynsail fod yn ystyriaeth o bwys wrth benderfynu ar geisiadau cynllunio ac rwy'n cytuno gyda'i safiad yn gyffredinol ar faterion o'r fath. Fodd bynnag, rwy'n deall hefyd bod angen sail tystiolaeth ar gyfer honiad o'r fath cyn y gellir dod i'r fath farn.

2.6 Ymddengys bod yr ymgynghorydd cynllunio yn dod i'r casgliad y byddai cynsail yn cael ei sefydlu am y rheswm *"that the two sites and developments share sufficient common factors"*. Dyma oedd y nodweddion cyffredin hyn :

- Mae'r ddau safle mewn ardal wledig gyda thai wedi eu gwasgaru yma ac acw yn ymyl y safleoedd.
- Mae'r tyrbinau o faint tebyg.
- Mae'r ceisiadau'n rhannu nodweddion tebyg o safbwynt cynllunio.
- Mae effaith y tyrbîn gwynt ar y cefn gwlad ac agoswydd y tai at y tyrbîn yn debygol o fod yn ystyriaethau o bwys wrth asesu rhinweddau'r ceisiadau.

78m together with the siting of associated infrastructure on land at Tyn Buarth, Penmynydd.

1.3 The current status of each application is as follows;

- Planning Application reference number 41C124, the "Ty Fry" application was withdrawn on the 26th January 2012 but was subsequently resubmitted on the 19th November 2012 under planning reference 41C124B and is currently undetermined.
- Planning Application reference number 41C66E, the "Marchynys" application remains undetermined as additional information is awaited.
- Planning Application reference number 41C110B, the "Tyn Buarth" application was returned undetermined to the applicant on the 1st September 2012 as additional information essential to enable the application to be determined was not submitted.

1.4 A copy of each application is exhibited at appendices 1,2 and 3 together with a plan identifying the position of the three application sites at appendices 4.

2.0 The precedent effect of application 41C124 on Councillor Foulkes' own applications.

2.1 I have read the Ombudman' s Report and the advice received from his independent planning adviser on whether or not the success of a planning application for a wind turbine in the locality could be regarded as setting a precedent for, and thereby potentially influencing, future turbine applications in the area.

2.2 The planning adviser concentrated primarily on the "Ty Fry" and "Marchynys" applications and stated that he believed "*that the two sites and developments share sufficient common factors that a precedent would be established by the grant of planning permission on one of the sites*" although he did qualify this by going on to state that the effect of such a precedent is "*always tempered by other planning factors*". The planning advisor concluded by saying that Cllr Foulkes support for the "Ty Fry" application "*has some bearing on the prospects of the other*".

2.5 I agree with the planning advisor that setting a precedent can be a material consideration in the determination of planning applications and with his general position on such matters. However, I also understand that before such a judgement can be reached there needs to be an evidence base for such an assertion.

Rwy'n cytuno fel mater o ffaith bod y ddau gais yn rhannu'r nodweddion cyffredin hyn.

2.7 Serch hynny, nid wyf wedi fy mherswadio bod y ffactorau cyffredin hyn a rennir, ynddynt eu hunain, yn arwain yn anorfod at y casgliad y byddai unrhyw gysail a sefydlid o'r fath arwyddocâd fel y byddai'n cael dylanwad o bwys wrth benderfynu ar y cais arall.

2.8 Mae ceisiadau am dyrbinau gwynt yn codi myrdd o faterion pellgyrhaeddol a chymhleth ac yn aml y mae'n rhaid eu pwysu a'u mesur a'u hasesu'n ofalus, e.e. polisi cynllunio, ystyriaethau trafndiaeth, treftadaeth ddiwylliannol, mwynderau preswyl, sŵn, cysgod gryniant, ecoleg, archeoleg, effaith ar y dirwedd ac ati. Gyda'i gilydd, gellir disgrifio'r rhain fel "*other planning factors that are particular to each site*". Yn ddieithriad yn fy mhrofiad i, y ffactorau cynllunio eraill hyn sydd yn hanfodol bwysig o ran asesu a yw ceisiadau o'r fath yn dderbyniol ai peidio.

2.9 Er y byddai'n rhaid asesu'n ofalus nifer os nad y cyfan o'r ffactorau hyn ym mhob cais, gofynnwyd i mi yn benodol roi rhywfaint o gyd-destun ynghylch topograffi'r ardal er mwyn rhoi gwell dealltwriaeth o'r goblygiadau o safbwynt effaith weledol y cais. Mae map OS ar raddfa 1: 25 000 (lle mae 4cm ar y map yn cyfateb i 1km ar y ddaear) ynghlwm fel Atodiad 5. Mae'r map hwn yn dangos llinellau amlinellol uchder yn yr ardal ac yn dangos bod topograffi'r dirwedd yn un o bantiau a bryniau bychan.

2.10 Oherwydd maint a lleoliad y ddau dyrbin yn y dirwedd hon, rwyf o'r farn y byddant yn nodweddion amlwg a fydd yn newid edrychiad yr ardal leol yn sylweddol. Efallai hefyd y bydd rhywfaint o ryngweledd o rai llefydd lle gellid gweld y ddau dyrbin ar yr un pryd, yn yr amgylchiadau hyn, byddai angen asesu nid yn unig effaith pob tyrbin yn unigol ond hefyd effaith gronol y ddau hefo'i gilydd.

2.11 Er eu bod yn weddol agos o safbwynt daearyddol, rwyf o'r farn bod y ddau safle'n ddigon pell oddi wrth ei gilydd (oddeutu 2.7km) ac yn yr amgylchiadau hyn, er bod y ffactorau cynllunio sy'n benodol i'r ddau safle yn debygol o fod yn debyg, byddwn yn rhagweld y byddai'r asesiad manwl o bob un o'r ffactorau hyn yn wahanol iawn.

2.12 Er bod yr ymgynghorydd cynllunio yn gywir pan mae'n dweud "*the community council's support or opposition to the wind turbine application at Tŷ Fry would be incorporated into the local planning authority's assessment*" nid wyf o'r farn bod hwn yn factor tyngedfennol wrth benderfynu ar geisiadau. Rwyf o'r farn y bydd y ffactorau cynllunio eraill sy'n benodol i bob safle, megis effaith weledol yn llawer mwy arwyddocaol a thyngedfennol.

3.0 Casgliadau

2.6 The planning advisor appears to reach his conclusion that a precedent would be established on the basis "*that the two sites and developments share sufficient common factors*". These common factors are identified as being;

- Both sites are in a rural location with a scatter of dwellings nearby.
- The turbines are of a similar size.
- The applications share similar features from a planning point of view.
- The effect of the wind turbine on the countryside and the proximity of dwellings to the turbine are likely to be material considerations in assessing the merits of the applications.

I agree that as a matter of fact the two applications do share these common factors.

2.7 Nevertheless I am not persuaded that these shared common factors in themselves inevitably lead to the conclusion that any precedent established would be of such significance as to have a material bearing in the determination of the other application.

2.8 Wind turbine applications raise a myriad of wide ranging and often complex issues that have to be weighed up and carefully evaluated e.g. planning policy, transport considerations, cultural heritage, residential amenity, noise, shadow flicker, ecology, archaeology, landscape impact etc. These collectively can be described as the "*other planning factors that are particular to each site*". Invariably, in my experience it is these other planning factors that are critical in assessing the acceptability or otherwise of such applications.

2.9 Whilst many if not all of these factors would need to be carefully evaluated in each application I have been asked specifically to provide some context of the topography of the area to give a greater understanding of the visual impact implications. An OS Map at a scale of 1: 25 000 (where 4cm on the map equates to 1km on the ground) is enclosed as appendices 5. This map displays contour lines of height in the locality and shows the landscape to be one of a gentle rolling topography.

2.10 It is my opinion that due to the scale and relative position of the two turbines within this landscape they will be prominent features that will introduce a significant change in the appearance of the locality. There may also be a degree of inter-visibility from certain viewpoints where both could be visible at the same time, in these circumstances not only will the impact of each turbine in isolation need to be evaluated but also the cumulative impact of both together.

2.11 Although being relatively close together in geographical terms I am of the opinion that there is a sufficient degree of separation between the two sites (at approximately 2.7 km) and in these circumstances I would anticipate that whilst the

3.1 Wedi ystyried yr uchod, rwy'n cytuno y gall cefnogaeth neu wrthwynebiad cyngor cymuned i'r tyrbîn gwynt yn Tŷ Fry gael effaith gynseiliol.

3.2 Serch hynny, rwyf o'r farn bod yr effaith yn un fechan ac o bwys cyfyngedig. Mae'r ffactorau cynllunio eraill sy'n benodol i bob safle yn fwy perthnasol ac arwyddocaol o lawer.

3.3 Wedi pwyso a mesur, rwyf o'r farn y gall unrhyw gynsail a sefydlir fod o bosib yn ystyriaeth o bwys ond y mae angen ei ffactora i mewn i unrhyw benderfyniad cynllunio, ac nid wyf yn ystyried bod honno'n ystyriaeth dyngedfennol yn yr achos hwn. O'r herwydd, yng nghyd-destun cyffredinol y ceisiadau, nid wyf wedi fy mherswadio bod yr effaith gynseiliol a nodwyd gan yr ymgynghorydd cynllunio yn un arwyddocaol.

Credaf fod yr holl ffeithiau yn y datganiad tyst hwn yn wir.

Llofnodwyd

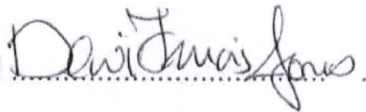

Dyddiedig 4 Chwefror 2013

Dewi Francis Jones

Rhestr o Atodiadau

Atodiad 1 – Copi o gais gynllunio 41C124 yn Ty Fry.

Atodiad 2 – Copi o gais cynllunio 41C66E ym Marchynys.

Atodiad 3 – Copi o gais cynllunio 41C110B yn Tyn Buarth

Atodiad 4 – Cynllun lleoliad graddfa 1:50 000 o'r 3 safle

Atodiad 5 – Map OS topograffeg graddfa 1:25 000.

planning factors particular to each site are likely to be the same the detailed assessment of each of these factors will be materially different.

2.12 Whilst the planning advisor correctly identifies that "*the community council's support or opposition to the wind turbine application at Ty Fry would be incorporated into the local planning authority's assessment*" I do not consider this to be a decisive factor in the determination of the applications. I am of the opinion that the other planning factors that are particular to each site, such as visual impact will far more significant and decisive.

3.0 Conclusions

3.1 Having considered the above I agree that a community council's support or opposition to the wind turbine at Ty Fry is capable of creating a precedent effect.

3.2 Nevertheless I am of the opinion that any such effect is slight and of limited weight. The other planning factors particular to each site are far more material and significant.

3.3 On balance, I consider that whilst any precedent created is potentially capable of being a material consideration that needs to be factored into any planning decision I do not consider that in this instance it is a decisive consideration. Consequently I am not persuaded that given the overall context of the applications that the precedent effect identified by the planning advisor is significant.

I believe that the facts in this witness statement are true.

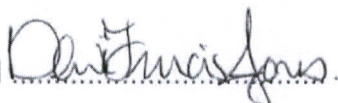
Signed 

Dated 4th February 2013

Dewi Francis Jones

List of Appendices.

Appendices 1 – Copy of planning application 41C124 at Ty Fry.

Appendices 2 - Copy of planning application 41C66E at Marchynys.

Appendices 3 - Copy of planning application 41C110B at Tyn Buarth

Appendices 4 – 1:50 000 scale location plan of all 3 sites.

Appendices 5 – 1:25 000 scale OS map of topography.

Ynys Môn
Isle of Anglesey
County Council

Ynys Môn
Isle of Anglesey
County Council

Ynys Môn
Isle of Anglesey
County Council

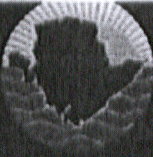

**CYNGOR SIR
YNYS MÔN
ISLE OF ANGLESEY
COUNTY COUNCIL**

Ynys Môn 01248 202436 Ffôn Ffôn 01248 750400

Planning Service
Environmental and Technical Services
Isle of Anglesey County Council
Council Offices
Llangefni
LL77 2TW

planning@anglesey.gov.uk
www.anglesey.gov.uk

Application for Planning Permission. Town and Country Planning Act 1990

Publication of applications on planning authority websites
Please note that the information provided on this application form and in supporting documents may be published on the Authority's website.
If you require any further clarification, please contact the Authority's planning department.

1. Applicant Name, Address and Contact Details

Title: First name: Surname:

Company name:

Street address:

Town/City:
County:
Country:

Postcode:

Telephone number:
Mobile number:
Fax number:

Country Code:
National Number:
Extension Number:

Email address:

Are you an agent acting on behalf of the applicant? Yes No

2. Agent Name, Address and Contact Details

Title: First Name: Surname:

Company name:

Street address:

Town/City:
County:
Country:
Postcode:

Telephone number:
Mobile number:
Fax number:

Country Code:
National Number:
Extension Number:

Email address:

3. Description of the Proposal

Please describe the proposed development including any change of use:

Has the building, work or change of use already started? Yes No

1. Site Address Details

Full postal address of the site (including full postcode where available)

House: Suffix:

House name:

Street address:

Town/City:

County:

Postcode:

Description:

Description of location or a grid reference
(must be completed if postcode is not known):

Easting:

Northing:

3. Pre-application Advice

Has assistance or prior advice been sought from the local authority about this application? Yes No

If Yes, please complete the following information about the advice you were given (this will help the authority to deal with this application more efficiently):

Officer name:

Title: First name: Surname:

Reference:

Date:

Details of the pre-application advice received:

Pre application meeting re policy context

5. Pedestrian and Vehicle Access, Roads and Rights of Way

Is a new or altered vehicle access proposed to or from the public highway? Yes No

Is a new or altered pedestrian access proposed to or from the public highway? Yes No

Are there any new public roads to be provided within the site? Yes No

Are there any new public rights of way to be provided within or adjacent to the site? Yes No

Do the proposals require any diversions/extinguishments and/or creation of rights of way? Yes No

If you answered Yes to any of the above questions, please show details on your plans/drawings and state the reference of the plan(s)/drawings(s)

Please refer to plan L.0-2

7. Waste Storage and Collection

Do the plans incorporate areas to store and aid the collection of waste? Yes No

Have arrangements been made for the separate storage and collection of recyclable waste? Yes No

3. Neighbour and Community Consultation

Have you consulted your neighbours or the local community about the proposal? Yes No

9. Authority Employee/Member

With respect to the Authority, I am:

- (a) a member of staff
- (b) an elected member
- (c) related to a member of staff
- (d) related to an elected member

Do any of these statements apply to you? Yes No

10. Materials

000153

10. Materials (continued)

Walls - description:

Description of existing materials and finishes:

Description of proposed materials and finishes:

Are you supplying additional information on submitted plan(s)/drawing(s)/design and access statement?

Yes No

11. Vehicle Parking

Please provide information on the existing and proposed number of on-site parking spaces:

Type of vehicle	Existing number of spaces	Total proposed (including spaces retained)	Difference in spaces
Cars	0	0	0
Light goods vehicles/public carrier vehicles	0	0	0
Motorcycles	0	0	0
Disability spaces	0	0	0
Cycle spaces	0	0	0
Other (e.g. Bus)	0	0	0
Short description of Other			

12. Foul Sewage

Please state how foul sewage is to be disposed of:

Mains sewer Package treatment plant Unknown
Septic tank Cess pit

Other
No connection

Are you proposing to connect to the existing drainage system?

Yes No Unknown

13. Assessment of Flood Risk

Is the site within an area at risk of flooding? (Refer to the Environment Agency's Flood Map showing flood zones 2 and 3 and consult Environment Agency standing advice and your local planning authority requirements for information as necessary.)

Yes No

If Yes, you will need to submit an appropriate flood risk assessment to consider the risk to the proposed site.

Is your proposal within 20 metres of a watercourse (e.g. river, stream or beck)?

Yes No

Will the proposal increase the flood risk elsewhere?

Yes No

How will surface water be disposed of?

Sustainable drainage system Main sewer Pond/lake
 Soakaway Existing watercourse

14. Biodiversity and Geological Conservation

To assist in answering the following questions refer to the guidance notes for further information on when there is a reasonable likelihood that any important biodiversity or geological conservation features may be present or nearby and whether they are likely to be affected by your proposals.

Having referred to the guidance notes, is there a reasonable likelihood of the following being affected adversely or conserved and enhanced within the application site, OR on land adjacent to or near the application site:

a) Protected and priority species

Yes, on the development site Yes, on land adjacent to or near the proposed development No

b) Designated sites, important habitats or other biodiversity features

Yes, on the development site Yes, on land adjacent to or near the proposed development No

c) Features of geological conservation importance

Yes, on the development site Yes, on land adjacent to or near the proposed development No

000154

15. Existing Use

Please describe the current use of the site:

Agricultural land

Is the site currently vacant? Yes No

Does the proposal involve any of the following:

Land which is known to be contaminated? Yes No

Land where contamination is suspected for all or part of the site? Yes No

A proposed use that would be particularly vulnerable to the presence of contamination? Yes No

Application advice

If you have said Yes to any of the above, you will need to submit an appropriate contamination assessment.

16. Trees and Hedges

Are there trees or hedges on the proposed development site? Yes No

And/or: Are there trees or hedges on land adjacent to the proposed development site that could influence the development or might be important as part of the local landscape character? Yes No

If Yes to either or both of the above, you will need to provide a full Tree Survey with accompanying plan before your application can be determined. Your Local Planning Authority should make clear on its website what the survey should contain, in accordance with the current 'BS5837: Trees in relation to construction - Recommendations'

17. Trade Effluent

Does the proposal involve the need to dispose of trade effluents or waste? Yes No

18. Residential Units

Does your proposal include the gain or loss of residential units? Yes No

19. All Types of Development: Non-residential Floorspace

Does your proposal involve the loss, gain or change of use of non-residential floorspace? Yes No

20. Employment

If known, please complete the following information regarding employees:

	Full-time	Part-time	Equivalent number of full-time
Existing employees	0	0	0
Proposed employees	0	0	0

21. Hours of Opening

If known, please state the hours of opening for each non-residential use proposed:

Use	Monday to Friday		Saturday		Sunday and Bank Holidays		Not Known
	Start Time	End Time	Start Time	End Time	Start Time	End Time	
B1C							<input type="checkbox"/>
B2							<input type="checkbox"/>
B8							<input type="checkbox"/>
C1							<input type="checkbox"/>
C2							<input type="checkbox"/>
D1							<input type="checkbox"/>
D2							<input type="checkbox"/>
Other							<input type="checkbox"/>

22. Site Area

What is the site area? hectares

23. Industrial or Commercial Processes and Machinery

Please describe the activities and processes which would be carried out on the site and the end products including plant, ventilation or air conditioning. Please include the

23. Industrial or Commercial Processes and Machinery (continued)

Is the proposal for a waste management development? Yes No

24. Hazardous Substances

Is any hazardous waste involved in the proposal? Yes No

25. Site Visit

Can the site be seen from a public road, public footpath, bridleway or other public land? Yes No

If the planning authority needs to make an appointment to carry out a site visit, whom should they contact? (Please select only one)

The agent The applicant Other person

26. Certificates (Certificate A)

Certificate of Ownership - Certificate A

Town and Country Planning (General Development Procedure) Order 1995 Certificate under Article 7

I certify/The applicant certifies that on the day 21 days before the date of this application nobody except myself/ the applicant was the owner (owner is a person with a freehold interest or leasehold interest with at least 7 years left to run) of any part of the land or building to which the application relates.

Title: Mr First name: Jamie Surname: Bradshaw
Person role: Agent Declaration date: 08/11/2011 Declaration made

26. Certificates (Agricultural Holdings Certificate)

Agricultural Holding Certificate

Town and Country Planning (General Development Procedure) Order 1995 Certificate under Article 7

Agricultural Land Declaration - You Must Select Either A or B

(A) None of the land to which the application relates is, or is part of an agricultural holding.

(B) I have/The applicant has given the requisite notice to every person other than myself/the applicant who, on the day 21 days before the date of this application, was a tenant of an agricultural holding on all or part of the land to which this application relates, as listed below:

Title: Mr First Name: Jamie Surname: Bradshaw
Person role: Agent Declaration date: 08/11/2011 Declaration Made

27. Declaration



I/we hereby apply for planning permission/consent as described in this form and the accompanying plans/drawings and additional information.

Date 08/11/2011

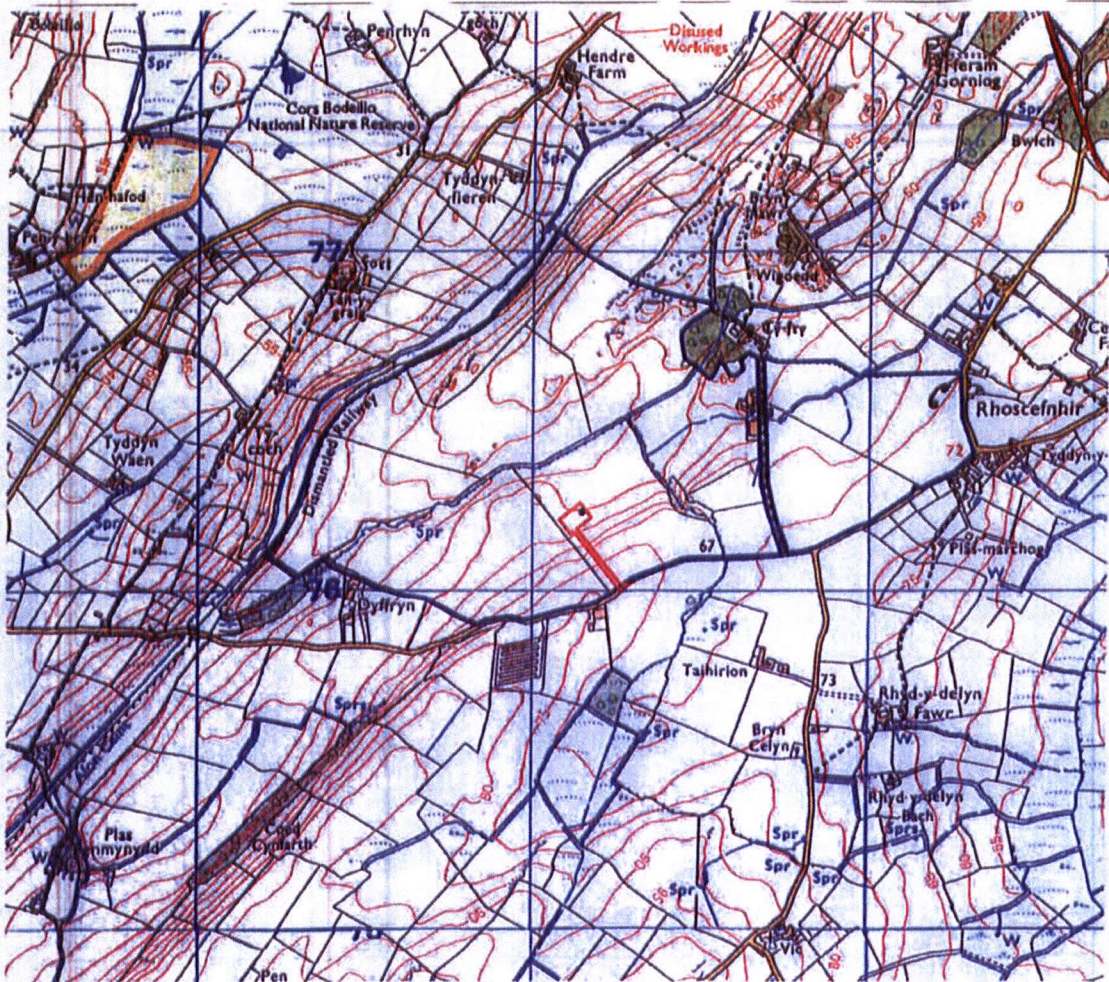
000156



WYG Planning & Design 
 Dafydd & Gwilym Jones
 Ty Fry Wind Turbine
 Site location **L0-1**

Key
 Application area
 Other land in applicants' control

REF. CASE: 4412/14	DATE RECEIVED: 05/01/15	RECEIVED BY: EON
APPLICATION NO. 4412/14	DATE RECEIVED: 05/01/15	
DYMOAD DESIGNED BY: 05/01/15		
DESIGNED BY: 05/01/15		
RECEIVED BY: EON		

0 0.1 0.2
 Scale 1:15,000 @ A3
 Does not scale from this sheet

North ↑

A073041-S L0-1D.cdr November 2011
 529, Pencoed, Longcross Court, 47 Newport Road, Cardiff, CF24 6AD
 Tel: +44 (0) 29 2072 9000 Fax: +44 (0) 29 2045 5321
 Email: info@wyg.com www.wyg.com
 Based upon the Ordnance Survey map with the permission of The Controller of Her Majesty's Stationery Office. © Crown copyright. WYG Environment Planning Transport Limited 2011. License No. AB 1000 17403
 © WYG Environment Planning Transport Ltd 2011. Registered in England Number: 1000000

000157

WYG Planning & Design
part of the WYG group



Dafydd & Gwilym Jones

Ty Fry Wind Turbine

Wind turbine
44m hub height

L0-3

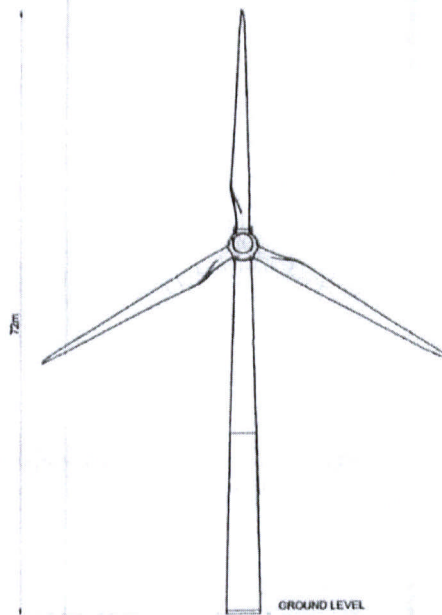
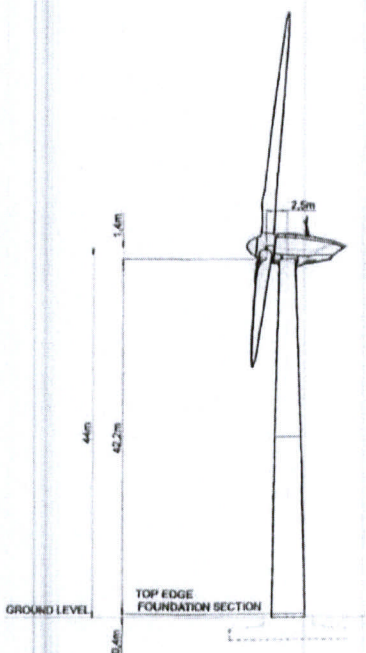

Note:
The turbine shown is:
44m hub height; 56m rotor diameter
and with an overall tip height of 72m

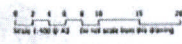

A073041-5 L0-3.cdr November 2011

3th Floor, Longcross Court, 47 Newport Road, Cardiff, CF24 6AD
Tel: +44 (0) 29 2072 6000 Fax: +44 (0) 29 2045 5321
Email: info@wyg.com www.wyg.com

Based upon the Ordnance Survey map with the permission of the Controller
of Her Majesty's Stationery Office. © Crown copyright. 10000 International
Planning Transport Limited 2011. License no: AB 1000 17609
© WYG Business Planning Transport Ltd 2011. Registered Engineer Number: 330524

000159

Gwasanaeth Cynllunio

Amgylchedd a Gwasanaethau Technegol
Cyngor Sir Ynys Môn
Swyddfeydd y Cyngor
Llangefni
LL77 7TW

cynllunio@ynymon.gov.uk
www.ynymon.gov.uk



CYNGOR SIR
YNYS MON
ISLE OF ANGLESEY
COUNTY COUNCIL

Ffôn/Tel: 01248 752428 Ffacs/Fax: 01248 752430

Planning Service

Environment and Technical Services
Isle of Anglesey County Council
Council Offices
Llangefni
LL77 7TW

planning@anglesey.gov.uk
www.anglesey.gov.uk

Application for Planning Permission.
Town and Country Planning Act 1990

Publication of applications on planning authority websites

Please note that the information provided on this application form and in supporting documents may be published on the Authority's website. If you require any further clarification, please contact the Authority's planning department.

1. Applicant Name, Address and Contact Details

Title: First name: Surname:

Company name:

Street address:

Town/City:

County:

Country:

Postcode:

Telephone number:

Country Code	National Number	Extension Number
<input type="text" value="0161"/>	<input type="text" value="2469800"/>	<input type="text"/>

Mobile number:

<input type="text"/>	<input type="text"/>	<input type="text"/>
----------------------	----------------------	----------------------

Fax number:

<input type="text"/>	<input type="text"/>	<input type="text"/>
----------------------	----------------------	----------------------

Email address:

Are you an agent acting on behalf of the applicant? Yes No

2. Agent Name, Address and Contact Details

Title: First Name: Surname:

Company name:

Street address:

Town/City:

County:

Country:

Postcode:

Telephone number:

Country Code	National Number	Extension Number
<input type="text"/>	<input type="text" value="01612469800"/>	<input type="text"/>

Mobile number:

<input type="text"/>	<input type="text"/>	<input type="text"/>
----------------------	----------------------	----------------------

Fax number:

<input type="text"/>	<input type="text"/>	<input type="text"/>
----------------------	----------------------	----------------------

Email address:

3. Description of the Proposal

Please describe the proposed development including any change of use:

Has the building, work or change of use already started? Yes No

4. Site Address Details

Full postal address of the site (including full postcode where available)

House: Suffix:
House name:
Street address:

Town/City:
County:
Postcode:

Description:

Description of location or a grid reference
(must be completed if postcode is not known):

Easting:
Northing:

5. Pre-application Advice

Has assistance or prior advice been sought from the local authority about this application? Yes No

If Yes, please complete the following information about the advice you were given (this will help the authority to deal with this application more efficiently):

Officer name:
Title: First name: Surname:
Reference:
Date:

Details of the pre-application advice received:

6. Pedestrian and Vehicle Access, Roads and Rights of Way

Is a new or altered vehicle access proposed to or from the public highway? Yes No

Is a new or altered pedestrian access proposed to or from the public highway? Yes No

Are there any new public roads to be provided within the site? Yes No

Are there any new public rights of way to be provided within or adjacent to the site? Yes No

Do the proposals require any diversions/extinguishments and/or creation of rights of way? Yes No

7. Waste Storage and Collection

Do the plans incorporate areas to store and aid the collection of waste? Yes No

Have arrangements been made for the separate storage and collection of recyclable waste? Yes No

8. Neighbour and Community Consultation

Have you consulted your neighbours or the local community about the proposal? Yes No

If Yes, please provide details:

9. Authority Employee/Member

With respect to the Authority, I am:

- (a) a member of staff
- (b) an elected member
- (c) related to a member of staff
- (d) related to an elected member

Do any of these statements apply to you? Yes No

10. Materials

Please state what materials (including type, colour and name) are to be used externally (if applicable):

000161

10. Materials (continued)

Vehicle access and hard standing - description:

Description of existing materials and finishes:

N/A

Description of proposed materials and finishes:

Crane platform, see DAS

Are you supplying additional information on submitted plan(s)/drawing(s)/design and access statement? Yes No

If Yes, please state references for the plan(s)/drawing(s)/design and access statement:

CE01-LL616PH-SITEPLAN
 CE01-LL616PH-SITLAY
 CE01-LL616PH-SITELOC
 CE01-LE616PH-010911DASMAR (design and access statement)

11. Vehicle Parking

Please provide information on the existing and proposed number of on-site parking spaces:

Type of vehicle	Existing number of spaces	Total proposed (including spaces retained)	Difference in spaces
Cars	0	0	0
Light goods vehicles/public carrier vehicles	0	0	0
Motorcycles	0	0	0
Disability spaces	0	0	0
Cycle spaces	0	0	0
Other (e.g. Bus)	0	0	0
Short description of Other			

12. Foul Sewage

Please state how foul sewage is to be disposed of:

Mains sewer Package treatment plant Unknown
 Septic tank Cess pit

Other

Are you proposing to connect to the existing drainage system? Yes No Unknown

13. Assessment of Flood Risk

Is the site within an area at risk of flooding? (Refer to the Environment Agency's Flood Map showing flood zones 2 and 3 and consult Environment Agency standing advice and your local planning authority requirements for information as necessary.) Yes No

If Yes, you will need to submit an appropriate flood risk assessment to consider the risk to the proposed site.

Is your proposal within 20 metres of a watercourse (e.g. river, stream or beck)? Yes No

Will the proposal increase the flood risk elsewhere? Yes No

How will surface water be disposed of?

Sustainable drainage system Main sewer Pond/lake
 Soakaway Existing watercourse

14. Biodiversity and Geological Conservation

To assist in answering the following questions refer to the guidance notes for further information on when there is a reasonable likelihood that any important biodiversity or geological conservation features may be present or nearby and whether they are likely to be affected by your proposals.

Having referred to the guidance notes, is there a reasonable likelihood of the following being affected adversely or conserved and enhanced within the application site, OR on land adjacent to or near the application site:

- a) Protected and priority species
 Yes, on the development site Yes, on land adjacent to or near the proposed development No
- b) Designated sites, important habitats or other biodiversity features
 Yes, on the development site Yes, on land adjacent to or near the proposed development No
- c) Features of geological conservation importance
 Yes, on the development site Yes, on land adjacent to or near the proposed development No

000162

15. Existing Use

Please describe the current use of the site:

Livestock Farming

Is the site currently vacant? Yes No

Does the proposal involve any of the following:

Land which is known to be contaminated? Yes No

Land where contamination is suspected for all or part of the site? Yes No

A proposed use that would be particularly vulnerable to the presence of contamination? Yes No

Application advice

If you have said Yes to any of the above, you will need to submit an appropriate contamination assessment.

16. Trees and Hedges

Are there trees or hedges on the proposed development site? Yes No

And/or: Are there trees or hedges on land adjacent to the proposed development site that could influence the development or might be important as part of the local landscape character? Yes No

If Yes to either or both of the above, you will need to provide a full Tree Survey with accompanying plan before your application can be determined. Your Local Planning Authority should make clear on its website what the survey should contain, in accordance with the current 'BS5837: Trees in relation to construction - Recommendations'

17. Trade Effluent

Does the proposal involve the need to dispose of trade effluents or waste? Yes No

18. Residential Units

Does your proposal include the gain or loss of residential units? Yes No

19. All Types of Development: Non-residential Floorspace

Does your proposal involve the loss, gain or change of use of non-residential floorspace? Yes No

20. Employment

If known, please complete the following information regarding employees:

	Full-time	Part-time	Equivalent number of full-time
Existing employees	0	0	0
Proposed employees	0	0	0

21. Hours of Opening

If known, please state the hours of opening for each non-residential use proposed:

Use	Monday to Friday		Saturday		Sunday and Bank Holidays		Not Known
	Start Time	End Time	Start Time	End Time	Start Time	End Time	
B1C							<input type="checkbox"/>
B2							<input type="checkbox"/>
B8							<input type="checkbox"/>
C1							<input type="checkbox"/>
C2							<input type="checkbox"/>
D1							<input type="checkbox"/>
D2							<input type="checkbox"/>
Other							<input type="checkbox"/>

22. Site Area

What is the site area? 00.10 hectares

23. Industrial or Commercial Processes and Machinery

Please describe the activities and processes which would be carried out on the site and the end products including plant, ventilation or air conditioning. Please include the type of machinery which may be installed on site:

23. Industrial or Commercial Processes and Machinery (continued)

Is the proposal for a waste management development? Yes No

24. Hazardous Substances

Is any hazardous waste involved in the proposal? Yes No

25. Site Visit

Can the site be seen from a public road, public footpath, bridleway or other public land? Yes No

If the planning authority needs to make an appointment to carry out a site visit, whom should they contact? (Please select only one)

The agent The applicant Other person

26. Certificates (Certificate A)

Certificate of Ownership - Certificate A

Town and Country Planning (General Development Procedure) Order 1995 Certificate under Article 7

I certify/The applicant certifies that on the day 21 days before the date of this application nobody except myself/ the applicant was the owner (owner is a person with a freehold interest or leasehold interest with at least 7 years left to run) of any part of the land or building to which the application relates.

Title: First name: Surname:
Person role: Declaration date: Declaration made

26. Certificates (Agricultural Holdings Certificate)

Agricultural Holding Certificate

Town and Country Planning (General Development Procedure) Order 1995 Certificate under Article 7

Agricultural Land Declaration - You Must Select Either A or B

(A) None of the land to which the application relates is, or is part of an agricultural holding.

(B) I have/The applicant has given the requisite notice to every person other than myself/the applicant who, on the day 21 days before the date of this application, was a tenant of an agricultural holding on all or part of the land to which this application relates, as listed below:

Title: First Name: Surname:
Person role: Declaration date: Declaration Made

27. Declaration

I/we hereby apply for planning permission/consent as described in this form and the accompanying plans/drawings and additional information.

Date

Marchynys Site Location Plan

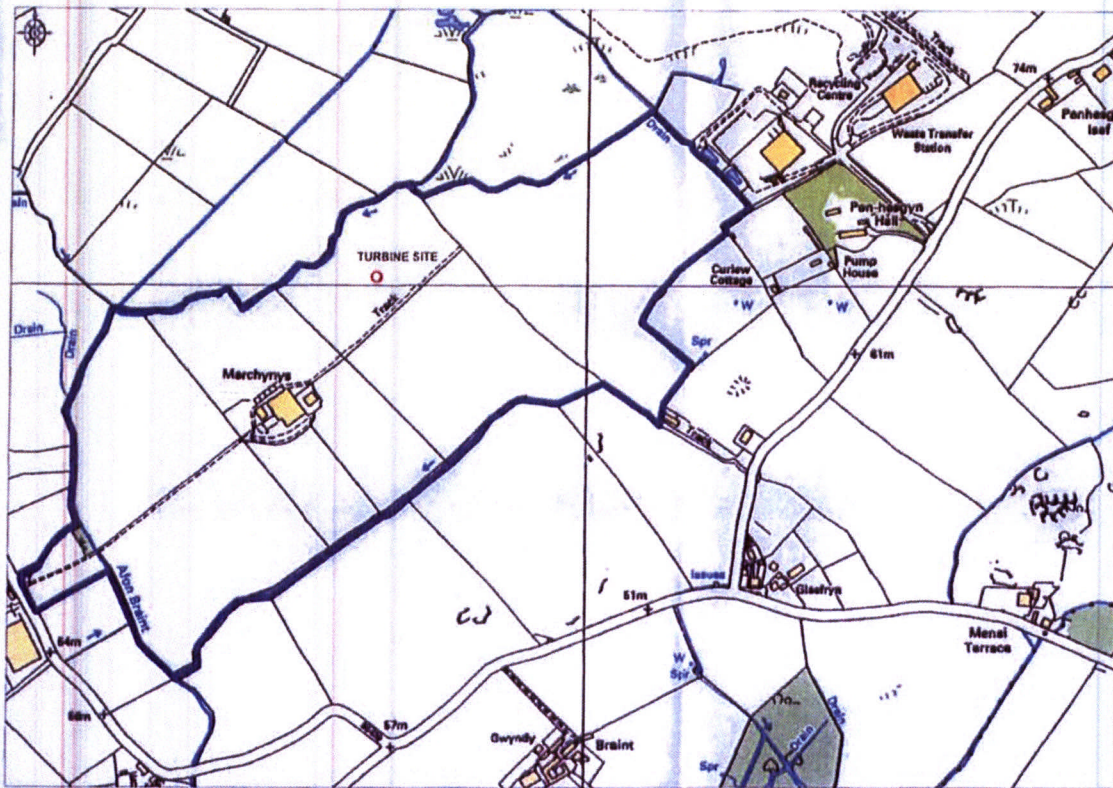

NOTES:
 PROPERTY BOUNDARY MARKED
 IN BLUE
 TURBINE SITE POSITION CIRCLED IN
 RED

DATE	FEB 2012
REF	CE01-LL616PH-LOCPLAN
CONSTANT ENERGY WIND · STORAGE · SOLAR	
MARCHYNYS WIND TURBINE	
PLANNING SITE LOCATION PLAN	
SCALE 1:5000 @ A3	



Location Plan 1:5,000 @ A3

291000

[FOR INFORMATION ONLY]

Document Ref: EWT000000

Project Name	General Arrangement
Project No.	1000600
Revision	02
Scale	1:1
Author	
Checked	
Drawn	
Project Manager	
Client	
Date	
Sheet No.	1 of 1

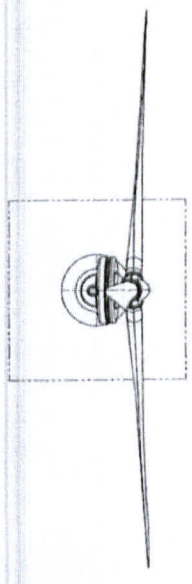
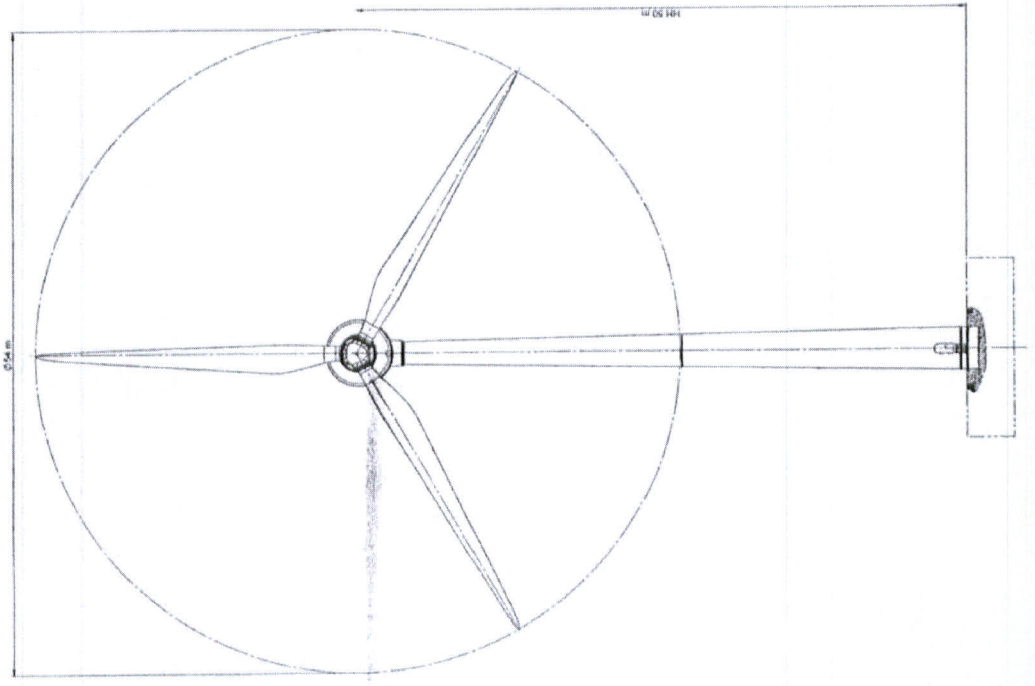
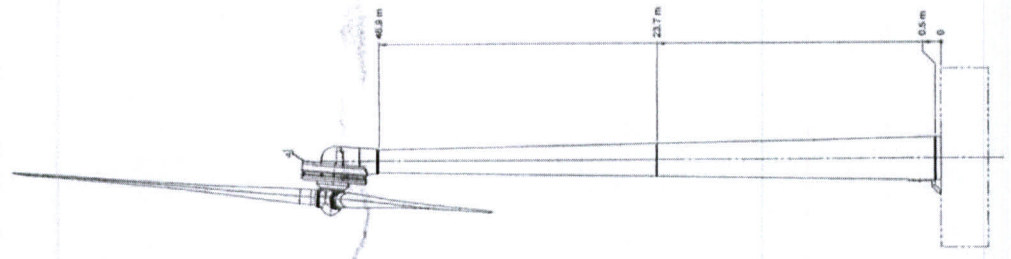
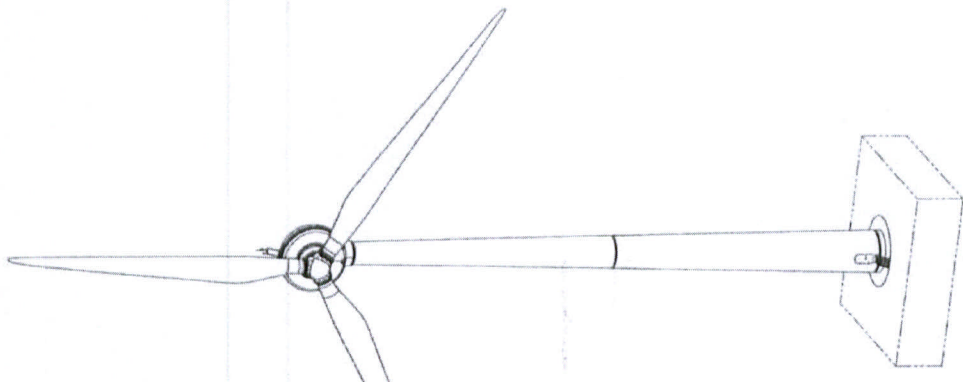

Gwasanaeth Cynllunio

Amgylchedd a Gwasanaethau Technegol
Cyngor Sir Ynys Môn
Swyddfeydd y Dyngor
Llangefni
LL77 7TW

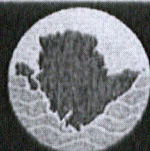

**CYNGOR SIR
YNYS MÔN
ISLE OF ANGLESEY
COUNTY COUNCIL**

Planning Service

Environment and Technical Services
Isle of Anglesey County Council
Council Offices
Llangefni
LL77 7TW

cynllunio@ynymon.gov.uk
www.ynymon.gov.uk

Ffôn/Tel: 01248 752428

Ffôn/Fax: 01248 752430

planning@anglesey.gov.uk
www.anglesey.gov.uk

**Application for Planning Permission.
Town and Country Planning Act 1990**

Publication of applications on planning authority websites

Please note that the information provided on this application form and in supporting documents may be published on the Authority's website. If you require any further clarification, please contact the Authority's planning department.

1. Applicant Name, Address and Contact Details

Title: First name: Surname:

Company name:

Street address:

Town/City:

County:

Country:

Postcode:

Telephone number: Country Code National Number Extension Number

Mobile number:

Fax number:

Email address:

Are you an agent acting on behalf of the applicant? Yes No

2. Agent Name, Address and Contact Details

Title: First Name: Surname:

Company name:

Street address:

Town/City:

County:

Country:

Postcode:

Telephone number: Country Code National Number Extension Number

Mobile number:

Fax number:

Email address:

3. Description of the Proposal

Please describe the proposed development including any change of use:

Has the building, work or change of use already started?

Yes No

000168

4. Site Address Details

Full postal address of the site (including full postcode where available)

Description:

House: Suffix:
House name: TYN Y BUARTH
Street address:
PENMYNYDD
Town/City: LLANFAIRPWLLGWYNGYLL
County:
Postcode: LL61 6PH

Description of location or a grid reference
(must be completed if postcode is not known):

Easting: 250585
Northing: 373541

5. Pre-application Advice

Has assistance or prior advice been sought from the local authority about this application? Yes No

If Yes, please complete the following information about the advice you were given (this will help the authority to deal with this application more efficiently):

Officer name:

Title: Mrs First name: Colette Surname: Redfern

Reference: 41C110A/SCR

Date: 27/07/2011

Details of the pre-application advice received:

Proposal does not require a EIA. Visual Impact Assessment required (see attached LVIA and associated documents)

6. Pedestrian and Vehicle Access, Roads and Rights of Way

Is a new or altered vehicle access proposed to or from the public highway? Yes No

Is a new or altered pedestrian access proposed to or from the public highway? Yes No

Are there any new public roads to be provided within the site? Yes No

Are there any new public rights of way to be provided within or adjacent to the site? Yes No

Do the proposals require any diversions/extinguishments and/or creation of rights of way? Yes No

7. Waste Storage and Collection

Do the plans incorporate areas to store and aid the collection of waste? Yes No

Have arrangements been made for the separate storage and collection of recyclable waste? Yes No

8. Neighbour and Community Consultation

Have you consulted your neighbours or the local community about the proposal? Yes No

If Yes, please provide details:

See attached Community Engagement Statement

9. Authority Employee/Member

With respect to the Authority, I am:

- (a) a member of staff
- (b) an elected member
- (c) related to a member of staff
- (d) related to an elected member

Do any of these statements apply to you? Yes No

10. Materials

Please state what materials (including type, colour and name) are to be used externally (if applicable):

000169

10. Materials (continued)

Vehicle access and hard standing - description:

Description of existing materials and finishes:

None

Description of proposed materials and finishes:

Crane Platform - see DAS

Are you supplying additional information on submitted plan(s)/drawing(s)/design and access statement? Yes No

If Yes, please state references for the plan(s)/drawing(s)/design and access statement:

CE02-LL616PH-010911DASTYN (design and access statement)
 CE02-LL616PH-SITEPLAN
 CE02-LL616PH-SITELAY
 CE02-LL616PH-SITELOC

11. Vehicle Parking

Please provide information on the existing and proposed number of on-site parking spaces:

Type of vehicle	Existing number of spaces	Total proposed (including spaces retained)	Difference in spaces
Cars	0	0	0
Light goods vehicles/public carrier vehicles	0	0	0
Motorcycles	0	0	0
Disability spaces	0	0	0
Cycle spaces	0	0	0
Other (e.g. Bus)	0	0	0
Short description of Other			

12. Foul Sewage

Please state how foul sewage is to be disposed of:

Mains sewer Package treatment plant Unknown
 Septic tank Cess pit

Other

Are you proposing to connect to the existing drainage system? Yes No Unknown

13. Assessment of Flood Risk

Is the site within an area at risk of flooding? (Refer to the Environment Agency's Flood Map showing flood zones 2 and 3 and consult Environment Agency standing advice and your local planning authority requirements for information as necessary.) Yes No

If Yes, you will need to submit an appropriate flood risk assessment to consider the risk to the proposed site.

Is your proposal within 20 metres of a watercourse (e.g. river, stream or beck)? Yes No

Will the proposal increase the flood risk elsewhere? Yes No

How will surface water be disposed of?

Sustainable drainage system Main sewer Pond/lake
 Soakaway Existing watercourse

14. Biodiversity and Geological Conservation

To assist in answering the following questions refer to the guidance notes for further information on when there is a reasonable likelihood that any important biodiversity or geological conservation features may be present or nearby and whether they are likely to be affected by your proposals.

Having referred to the guidance notes, is there a reasonable likelihood of the following being affected adversely or conserved and enhanced within the application site, OR on land adjacent to or near the application site:

a) Protected and priority species

Yes, on the development site Yes, on land adjacent to or near the proposed development No

b) Designated sites, important habitats or other biodiversity features

Yes, on the development site Yes, on land adjacent to or near the proposed development No

c) Features of geological conservation importance

Yes, on the development site Yes, on land adjacent to or near the proposed development No

000170

15. Existing Use

Please describe the current use of the site:

Livestock Farming

Is the site currently vacant? Yes No

Does the proposal involve any of the following:

Land which is known to be contaminated? Yes No

Land where contamination is suspected for all or part of the site? Yes No

A proposed use that would be particularly vulnerable to the presence of contamination? Yes No

Application advice

If you have said Yes to any of the above, you will need to submit an appropriate contamination assessment.

16. Trees and Hedges

Are there trees or hedges on the proposed development site? Yes No

And/or: Are there trees or hedges on land adjacent to the proposed development site that could influence the development or might be important as part of the local landscape character? Yes No

If Yes to either or both of the above, you will need to provide a full Tree Survey with accompanying plan before your application can be determined. Your Local Planning Authority should make clear on its website what the survey should contain, in accordance with the current 'BS5837: Trees in relation to construction - Recommendations'

17. Trade Effluent

Does the proposal involve the need to dispose of trade effluents or waste? Yes No

18. Residential Units

Does your proposal include the gain or loss of residential units? Yes No

19. All Types of Development: Non-residential Floorspace

Does your proposal involve the loss, gain or change of use of non-residential floorspace? Yes No

20. Employment

If known, please complete the following information regarding employees:

	Full-time	Part-time	Equivalent number of full-time
Existing employees	0	0	0
Proposed employees	0	0	0

21. Hours of Opening

If known, please state the hours of opening for each non-residential use proposed:

Use	Monday to Friday		Saturday		Sunday and Bank Holidays		Not Known
	Start Time	End Time	Start Time	End Time	Start Time	End Time	
B1C							<input type="checkbox"/>
B2							<input type="checkbox"/>
B8							<input type="checkbox"/>
C1							<input type="checkbox"/>
C2							<input type="checkbox"/>
D1							<input type="checkbox"/>
D2							<input type="checkbox"/>
Other							<input type="checkbox"/>

22. Site Area

What is the site area? 00.10 hectares

23. Industrial or Commercial Processes and Machinery

Please describe the activities and processes which would be carried out on the site and the end products including plant, ventilation or air conditioning. Please include the type of machinery which may be installed on site:

Installation of 1 500kw wind turbine (50m to hub height) and associated infrastructure.

23. Industrial or Commercial Processes and Machinery (continued)

Is the proposal for a waste management development? Yes No

24. Hazardous Substances

Is any hazardous waste involved in the proposal? Yes No

25. Site Visit

Can the site be seen from a public road, public footpath, bridleway or other public land? Yes No

If the planning authority needs to make an appointment to carry out a site visit, whom should they contact? (Please select only one)

The agent The applicant Other person

26. Certificates (Certificate A)

Certificate of Ownership - Certificate A

Town and Country Planning (General Development Procedure) Order 1995 Certificate under Article 7

I certify/The applicant certifies that on the day 21 days before the date of this application nobody except myself/ the applicant was the owner (owner is a person with a freehold interest or leasehold interest with at least 7 years left to run) of any part of the land or building to which the application relates.

Title: First name: Surname:

Person role: Declaration date: Declaration made

26. Certificates (Agricultural Holdings Certificate)

Agricultural Holding Certificate

Town and Country Planning (General Development Procedure) Order 1995 Certificate under Article 7

Agricultural Land Declaration - You Must Select Either A or B

(A) None of the land to which the application relates is, or is part of an agricultural holding.

(B) I have/The applicant has given the requisite notice to every person other than myself/the applicant who, on the day 21 days before the date of this application, was a tenant of an agricultural holding on all or part of the land to which this application relates, as listed below:

Title: First Name: Surname:

Person role: Declaration date: Declaration Made

27. Declaration

I/we hereby apply for planning permission/consent as described in this form and the accompanying plans/drawings and additional information.

Date:

000172

Tyn Buarth Site Location Plan

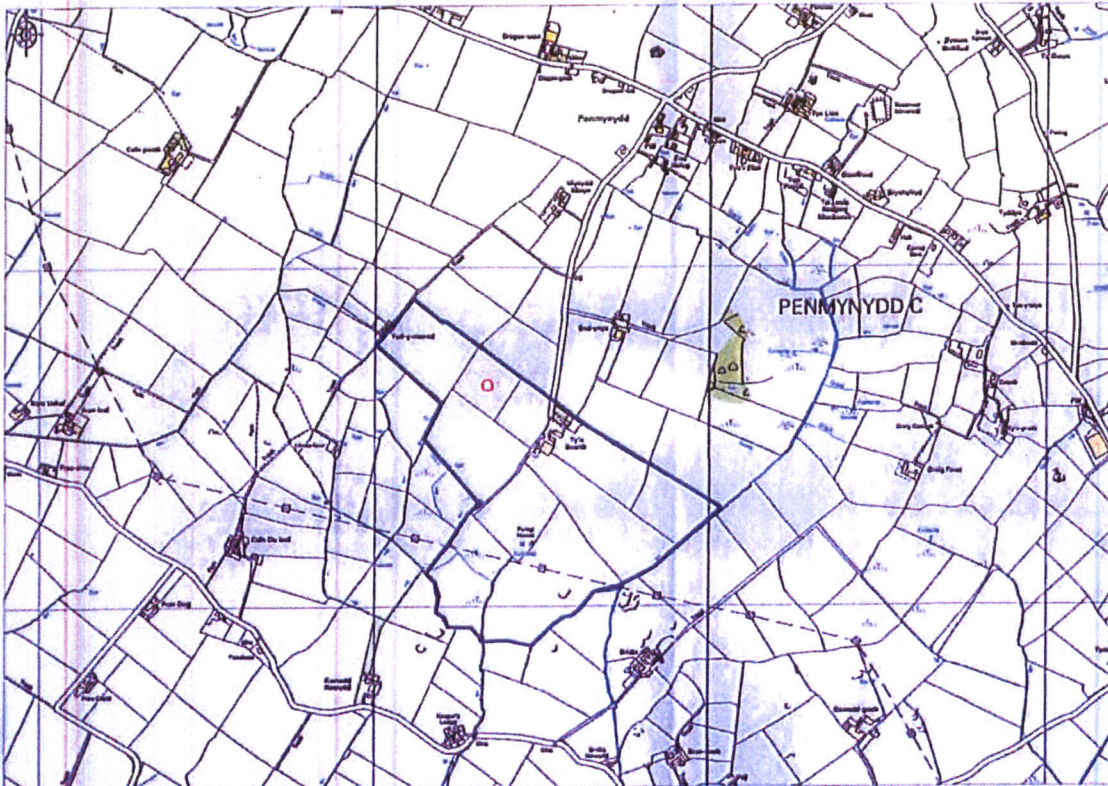

NOTES:	
PROPERTY BOUNDARY MARKED IN BLUE TURBINE SITE POSITION CIRCLED RED	
DATE	FEB 2012
REF	CE02-LL816PH-SITELOC
	
TYN BUARTH WIND TURBINE	
PLANNING SITE LOCATION PLAN	
SCALE 1:10000 @ A3	

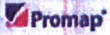

Site Location Plan 1:10,000 @ A3

000173

1883

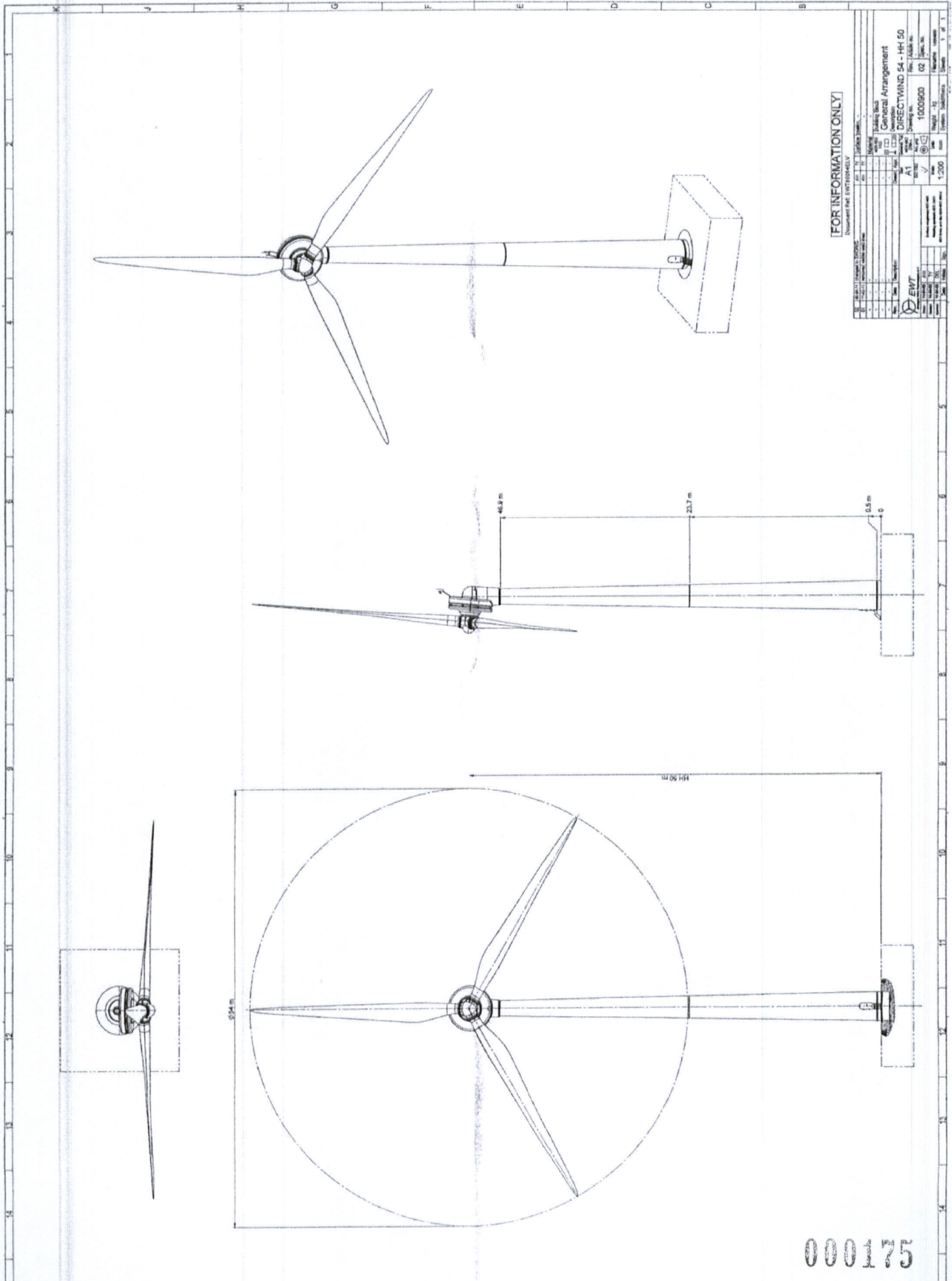

[FOR INFORMATION ONLY]
 Document non contractuel

PROJET Nom du projet : General Arrangement Révisé par : 1000600 Date : 02 Version : 02		CLIENT Nom du client : DIRECTWIND S4 - HH 50 Adresse : 1000600 Téléphone : 1000600 Fax : 1000600 E-mail : 1000600 Site Web : 1000600	
PROJET Nom du projet : General Arrangement Révisé par : 1000600 Date : 02 Version : 02		CLIENT Nom du client : DIRECTWIND S4 - HH 50 Adresse : 1000600 Téléphone : 1000600 Fax : 1000600 E-mail : 1000600 Site Web : 1000600	

000175

000176

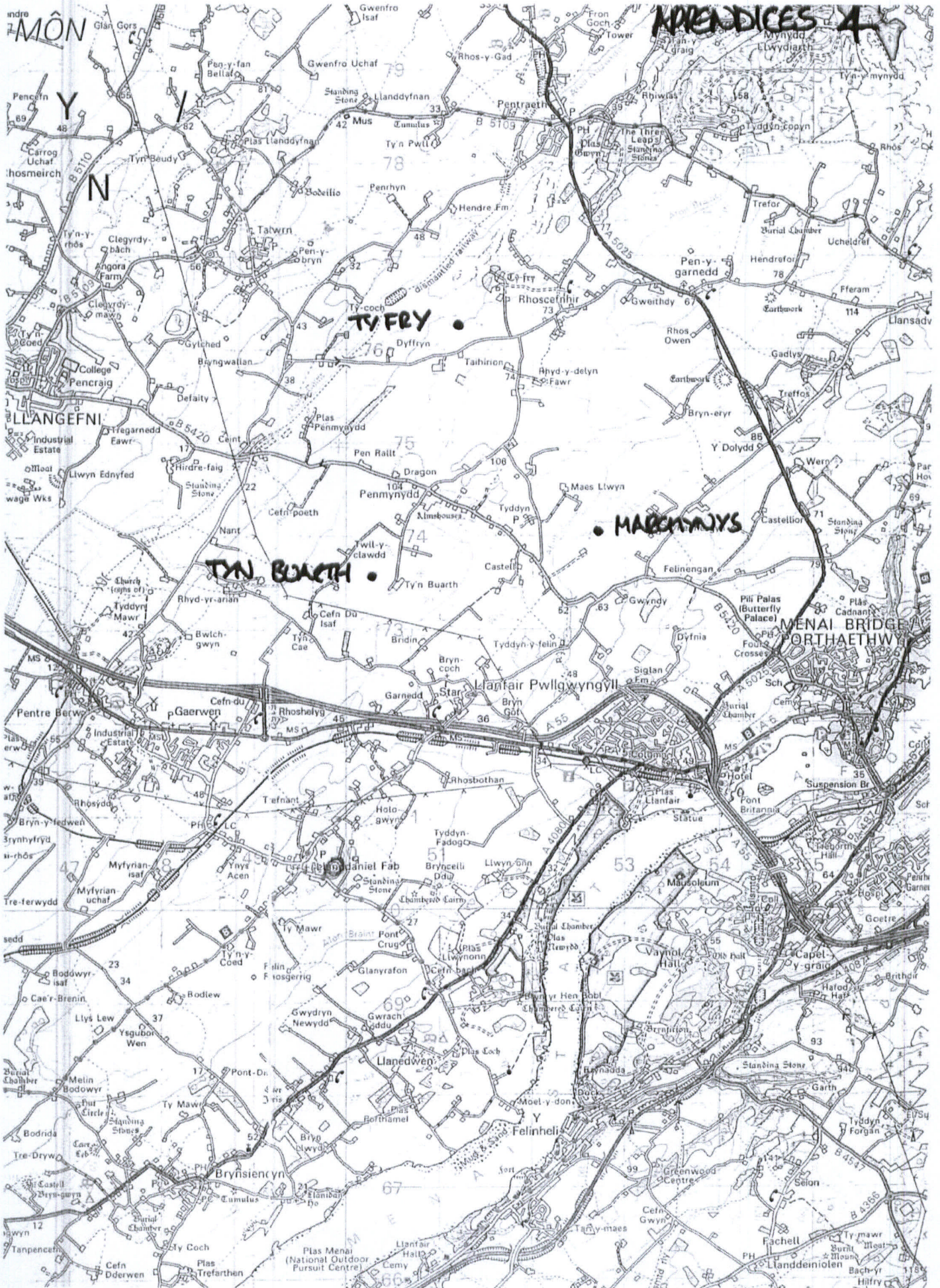

000178

DOGFEN / DOCUMENT

5

000181

Cyngor Sir Ynys Môn

Pwyllgor Safonau

Gweithdrefn ar gyfer Gwrandawiadau Safonau Lleol

1 Rhagarweiniad

Mae'r weithdrefn hon yn amlinellu sut y bydd y Cyngor Sir yn penderfynu cwynion am gamymddygiad aelodau.

2 Dehongliad

- (a) Mae "Aelod" yn golygu'r aelod o'r awdurdod sy'n destun yr honiad sy'n cael sylw gan y Pwyllgor Safonau, ac eithrio lle dywedir yn wahanol. Mae hefyd yn cynnwys cynrychiolydd enwebedig yr Aelod.
- (b) Mae "Swyddog Ymchwilio" yn golygu Ombwdsmon Gwasanaethau Cyhoeddus Cymru (yr Ombwdsmon), ac mae'n cynnwys ei gynrychiolydd/chynrychiolydd enwebedig. Yn achos materion a gyfeiriwyd ar gyfer ymchwiliad lleol, mae cyfeiriadau at y Swyddog Ymchwilio yn golygu'r sawl a benodwyd gan y Swyddog Monitro i gynnal yr ymchwiliad.
- (c) "Y Mater" yw pwnc adroddiad y Swyddog Ymchwilio.
- (ch) Mae "Y Pwyllgor Safonau" yn cyfeirio at y Pwyllgor Safonau neu at unrhyw is-bwyllgor safonau y mae wedi dirprwyo'r gwrandawriad iddo.
- (d) Mae "Swyddog Cymorth Pwyllgor" yn golygu Swyddog o'r Awdurdod sy'n gyfrifol am gynorthwyo'r Pwyllgor Safonau wrth iddo gyflawni ei swyddogaethau ac am gofnodi penderfyniadau'r Pwyllgor Safonau.
- (dd) Mae "Ymgynghorydd Cyfreithiol" yn golygu'r swyddog sy'n gyfrifol am ddarparu cymorth cyfreithiol i'r Pwyllgor Safonau. Gall y swyddog hwnnw fod yn Swyddog Monitro, swyddog arall yn yr awdurdod â chymwysterau cyfreithiol, neu rywun a benodwyd i'r pwrpas o'r tu allan i'r awdurdod.
- (e) Mae "Cadeirydd" yn cyfeirio at y person sy'n llywyddu yn y gwrandawriad.
- (f) Mae "Achwynydd" yn golygu'r person neu'r personau a wnaeth yr honiad gwreiddiol yr ymchwiliwyd iddo.

3 Diwygio'r Weithdrefn

Gall y Cadeirydd gytuno i amrywio'r weithdrefn hon mewn unrhyw achos penodol os yw ef/hi o'r farn bod angen gwneud hynny er budd tegwch.

000132

Isle of Anglesey County Council

Standards Committee

Procedure for Local Standards Hearings

1 Introduction

This procedure sets out how the County Council will determine complaints of Member misconduct

2 Interpretation

- (a) "Member" means the Member of the Council who is the subject of the allegation being considered by the Standards Committee, unless stated otherwise. It also includes the Member's nominated representative.
- (b) "Investigating Officer" means the Public Services Ombudsman for Wales (PSOW), and includes his or her nominated representative. In the case of matters that have been referred for local investigation, references to the Investigating Officer means the person appointed by the Monitoring Officer to undertake that investigation.
- (c) "The Matter" is the subject matter of the Investigating Officer's report.
- (ch) "The Standards Committee" refers to the Standards Committee, or to any Standards Sub-Committee, to which it has delegated the conduct of the hearing.
- (d) "The Committee Support Officer" means an Officer of the Council responsible for supporting the Standards Committee's discharge of its functions and recording the decisions of the Standards Committee.
- (dd) "The Legal Advisor" means the Officer responsible for providing legal advice to the Standards Committee. This may be the Monitoring Officer, another legally qualified Officer of the Council, or someone appointed for this purpose from outside the Council.
- (e) "The Chairman" refers to the person presiding at the hearing
- (f) "The Complainant" means the person or persons who made the original allegation which has been investigated.

3 Modification of Procedure

The Chairman may agree to vary this procedure in any particular instance where he/she is of the opinion that such a variation is necessary in the interests of fairness.

000183

4 Cynrychiolaeth

Gall cyfreithiwr, cwnsler neu - gyda chaniatâd y Pwyllgor Safonau - berson arall gynrychioli'r Aelod ar unrhyw adeg yn y weithdrefn hon neu ddod i'r gwrandawriad gyda'r aelod. Noder mai'r aelod sy'n gyfrifol am gwrdd â chostau cynrychiolaeth o'r fath, ac eithrio lle mae'r Pwyllgor Safonau wedi cytuno'n benodol i gwrdd â'r cyfan o'r gost honno neu ran ohoni.

5 Penderfyniad i gynnal gwrandawriad lleol

- (a) Ar ôl derbyn adroddiad yr Ombwdsmon, neu adroddiad Swyddog Ymchwilio, bydd y Swyddog Monitro yn cyfeirio'r adroddiad hwnnw i'r Pwyllgor Safonau a fydd yn penderfynu un ai –
 - (i) Bod tystiolaeth o fethiant gan yr Aelod i gydymffurfio gyda'r Côd Ymddygiad, neu
 - (ii) Y dylai'r mater fod yn destun gwrandawriad lleol.
- (b) Os yw'r Pwyllgor Safonau yn penderfynu bod tystiolaeth o fethiant i gydymffurfio gyda'r Côd Ymddygiad, bydd y Swyddog Monitro yn rhoi gwybod i'r Aelod a'r Achwynydd am hynny.
- (c) Os bydd y Pwyllgor Safonau yn penderfynu cynnal gwrandawriad lleol ar gyfer y mater, bydd y Swyddog Monitro yn cynnal y broses cyn-gwrandawriad fel y mae wedi ei hamlinellu isod.

6 Y Weithdrefn Cyn-Gwrandawriad

Yn dilyn penderfyniad gan y Pwyllgor Safonau i gynnal gwrandawriad lleol ar gyfer mater penodol, bydd y Swyddog Monitro yn:

- (a) Trefnu dyddiad ar gyfer gwrandawriad y Pwyllgor Safonau fel y penderfynwyd arno gan y Cadeirydd;
- (b) Anfon copi o'r adroddiad i'r Aelod a rhoi gwybod iddo am ddyddiad, amser a man cyfarfod y gwrandawriad;
- (c) Anfon copi o'r adroddiad i'r Achwynydd a rhoi gwybod iddo am ddyddiad, amser a man cyfarfod y gwrandawriad;
- (ch) Rhoi gwybod i'r Cyngor Cymuned am y mater ynghyd â dyddiad, amser a man cyfarfod y gwrandawriad (os yw'r mater yn ymwneud ag ymddygiad Cynghorydd Cymuned);
- (d) Rhoi gwybod i'r Swyddog Ymchwilio am ddyddiad, amser a man cyfarfod y gwrandawriad;
- (dd) Gofyn i'r Swyddog gwblhau a dychwelyd y ffurflenni cyn-gwrandawriad sydd wedi eu hatodi wrth y Weithdrefn hon cyn pen 14 diwrnod o'u derbyn;
- (e) Yn wyneb unrhyw ffurflenni cyn-gwrandawriad a ddychwelwyd gan yr Aelod, bydd y Swyddog Monitro yn penderfynu a fydd y Pwyllgor Safonau angen i'r

000184

4 Representation

The Member may be represented or accompanied at any stage of this procedure by a Solicitor, Counsel or, with the permission of the Standards Committee, by another person. Note that the cost of such representation must be met by the Member, unless the indemnities Sub Committee has expressly agreed to meet all or any parts of that cost.

5 Decision to conduct a local hearing

- (a) Upon receipt of the PSOW's report, or the report of an Investigating Officer, the Monitoring Officer shall refer that report to the Standards Committee, which shall resolve either –
 - (i) That there is no evidence of a failure by the Member to comply with the Code of Conduct, or
 - (ii) That the matter should go for a local hearing.
- (b) Where the Standards Committee resolves that there is no evidence of a failure to comply with the Code of Conduct, the Monitoring Officer shall notify the Member and the Complainant accordingly.
- (c) Where the Standards Committee resolves that the matter shall go to a local hearing, the Monitoring Officer shall conduct the pre-hearing procedure as set out below.

6 Pre-Hearing Procedure

Following a resolution of the Standards Committee to conduct a local hearing on a matter, the Monitoring Officer shall:

- (a) Arrange a date for the Standards Committee's hearing as determined by the Chairman;
- (b) Send a copy of the report to the Member and advise him of the date, time and place for the hearing;
- (c) Send a copy of the report to the Complainant and advise him of the date, time and place for the hearing;
- (ch) Notify the Community Council of the matter and of the date, time and place of the hearing (where the matter relates to the conduct of a Community Councillor);
- (d) Notify the Investigating Officer of the date, time and place of the hearing;
- (dd) Request the Member to complete and return the Pre-Hearing Forms appended to this Procedure within 14 days of receipt;
- (e) In the light of any Pre-Hearing Forms returned by the Member, determine whether the Standards Committee will require the attendance of the

000185

Swyddog Ymchwilio ac unrhyw dystion¹ ychwanegol fod yn bresennol yn y gwrandawriad, gan gynnwys yr Achwynydd, fel bod modd i'r gwrandawriad ddod i gasgliad sydd wedi cael ystyriaeth briodol yn y gwrandawriad, a threfnu iddynt fynychu.

- (f) Gofyn i'r Cadeirydd wneud y fath gyfarwyddiadau ynghylch cynnal y gwrandawriad ac y bydd eu hangen ar gyfer cynnal y gwrandawriad yn effeithiol, gyda'r fath gyfarwyddiadau yn rhoi sylw i faterion fel –
 - (i) Yr amser y bydd y Pwyllgor Safonau yn cyfarfod i gynnal y gwrandawriad;
 - (ii) Unrhyw faterion sy'n cael eu derbyn fel y maent ac nad oes angen tystiolaeth ar eu cyfer;
 - (iii) Y tystion a glywir a'r adegau pryd ddylent fod yn bresennol; a
 - (iv) Presenoldeb tystion pan nad ydynt yn rhoi tystiolaeth.
- (ff) Paratoi Adroddiad Crynhoi Cyn-gwrandawriad yn amlinellu cwrs yr honiad, yr ymchwiliad a'r broses cyn-gwrandawriad ac yn dwyn sylw at y materion y bydd angen i'r Pwyllgor Safonau roi sylw iddynt, a
- (g) Trefnu gyda'r Swyddog Cymorth Pwyllgor bod y rhaglen ar gyfer y gwrandawriad, ynghyd ag Adroddiad Crynhoi Cyn-gwrandawriad y Swyddog Monitro, adroddiad y Swyddog Ymchwilio ac unrhyw ddogfennau perthnasol eraill yn cael eu hanfon at:
 - (i) Pob aelod o'r Pwyllgor Safonau fydd yn cynnal y gwrandawriad;
 - (ii) Yr Aelod.
 - (iii) Y sawl a wnaeth yr honiad, a
 - (iv) Y Swyddog Ymchwilio

7 Cyngor Cyfreithiol

Gall y Pwyllgor Safonau gymryd cyngor cyfreithiol gan ei ymgynghorydd cyfreithiol ar unrhyw adeg yn ystod y gwrandawriad neu tra bydd yn ystyried y canlyniad. Dylid rhannu sylwedd unrhyw gyngor cyfreithiol a roddir i'r Pwyllgor Safonau gyda'r Aelod a'r Swyddog Ymchwilio os ydynt yn bresennol.

8 Paratoi ar gyfer y Cyfarfod

Ar gychwyn y gwrandawriad, bydd y Cadeirydd yn cyflwyno pob un o aelodau'r Pwyllgor Safonau, yr aelod (os yw'n bresennol), y Swyddog Ymchwilio (os yw'n bresennol) ac unrhyw swyddogion eraill sydd yn bresennol, ac yna bydd yn esbonio'r drefn y bydd y Pwyllgor Safonau yn ei dilyn wrth gynnal y gwrandawriad.

9 Materion trefniadol rhagarweiniol

Yna bydd y Pwyllgor Safonau yn delio gyda'r materion trefniadol rhagarweiniol isod yn y drefn ganlynol:

- (a) Ymddiheuriadau am absenoldeb

¹ Os yw'r Aelod yn herio unrhyw ganfyddiad ffaith yn adroddiad y Swyddog Ymchwilio, bydd angen i'r Pwyllgor Safonau glywed tystiolaeth gan dyst uniongyrchol, lle bynnag y mae hynny'n bosib.

Investigating Officer and any additional witnesses¹, including the Complainant, at the hearing to enable it to come to a properly considered conclusion at the hearing, and arrange for their attendance;

- (f) Request the Chairman to make such Directions as to the conduct of the hearing as may be necessary for the effective conduct of the hearing, which Directions may address such issues as –
 - (i) The time that the Standards Committee will sit to conduct the hearing;
 - (ii) Any matters which are to be taken as read and on which evidence is not required;
 - (iii) The witnesses to be heard and the times at which they should be present; and
 - (iv) The presence of witnesses when not giving evidence.
- (ff) Prepare a Pre-Hearing Summary Report setting out the course of the allegation, investigation and Pre-Hearing Process and high-lighting the issues which the Standards Committee will need to address, and
- (g) Arrange with the Committee Support Officer that the agenda for the hearing, together with the Monitoring Officer's Pre-Hearing Summary Report, the Investigating Officer's report and any other relevant documents are sent to:
 - (i) All members of the Standards Committee who will conduct the hearing;
 - (ii) The Member;
 - (iii) The person who made the allegation, and
 - (iv) The Investigating Officer.

7 Legal Advice

The Standards Committee may take legal advice from its legal advisor at any time during the hearing or while they are considering the outcome. The substance of any legal advice given to the Standards Committee should be shared with the Member and the Investigating Officer if they are present.

8 Setting the Scene

At the start of the hearing, the Chairman shall introduce each of the Members of the Standards Committee, the Member (if present), the Investigating Officer (if present) and any other Officers present, and shall then explain the procedure which the Standards Committee will follow in the conduct of the hearing.

9 Preliminary Procedural Issues

The Standards Committee shall then deal with the following preliminary procedural matters in the following order:

¹ Where the Member has indicated that he disputes any finding of fact in the Investigating Officer's report, the Standards Committee will need to hear evidence on the disputed point from a first hand witness, wherever possible.

(b) Datganiadau o ddiddordeb

Bydd y Cadeirydd yn gofyn i aelodau'r Pwyllgor Safonau ddatgelu bodolaeth a natur unrhyw ddiddordebau personol neu ddiddordebau sydd yn rhagfarnu a fo ganddynt yn y mater, ac yn gofyn iddynt dynnu'n ôl o ystyried y mater os oes angen.

(c) Cworwm

Bydd y Cadeirydd yn cadarnhau bod gan y Pwyllgor Safonau gworwm²

(ch) Trefn y gwrandawriad

Bydd y Cadeirydd yn cadarnhau bod pawb sy'n bresennol yn ymwybodol o'r drefn y bydd y Pwyllgor Safonau yn ei dilyn wrth benderfynu'r mater.

(d) Bwrw ymlaen yn absenoldeb yr aelod

Onid yw'r Aelod yn bresennol ar gychwyn y gwrandawriad;

(i) bydd y Cadeirydd yn gofyn i'r Swyddog Monitro a yw'r Aelod wedi dweud nad yw'n bwriadu dod i'r gwrandawriad;

(ii) bydd y Pwyllgor Safonau wedyn yn ystyried unrhyw resymau a roddwyd gan yr Aelod am beidio â dod i'r gwrandawriad a bydd yn penderfynu a yw'n fodlon bod digon o reswm am y fath fethiant i fynychu.

(iii) Os bydd y Pwyllgor Safonau yn fodlon gyda'r fath resymau, bydd yn gohirio'r gwrandawriad tan ddyddiad arall.

(iv) Onid yw'r Pwyllgor Safonau yn fodlon gyda'r fath resymau, neu onid yw'r aelod wedi rhoi unrhyw fath rhesymau, bydd y Pwyllgor Safonau yn penderfynu a ddylid ystyried y mater a gwneud penderfyniad yn absenoldeb yr Aelod ynteu ohirio'r gwrandawriad tan ddyddiad arall.

(dd) Cau allan y Wasg a'r Cyhoedd

Gall y Pwyllgor Safonau gau allan y wasg a'r cyhoedd o ran o'i drafodaethau ar y mater dan sylw neu o'r trafodaethau cyfan, os yw'n ymddangos yn debygol y bydd gwybodaeth gyfrinachol neu eithriedig yn cael ei datgelu yng nghwrs y trafodaethau.

Bydd y Cadeirydd yn gofyn i'r Aelod, y Swyddog Ymchwilio a'r Ymgynghorydd Cyfreithiol i'r Pwyllgor Safonau a ydynt yn dymuno gofyn i'r Pwyllgor Safonau gau allan y wasg a'r cyhoedd o ran o'r gwrandawriad neu o'r cyfan ohono. Os bydd unrhyw aelod yn gwneud cais o'r fath, bydd y Cadeirydd yn gofyn iddynt

²

Ni fydd gan gyfarfod o'r Pwyllgor Safonau gworwm oni bai bod o leiaf 3 aelod o'r Pwyllgor Safonau yn bresennol ar gyfer y cyfarfod i gyd. Rhaid i'r Cadeirydd fod yn aelod Annibynnol, a rhaid i o leiaf hanner aelodau'r Pwyllgor sy'n bresennol fod yn aelodau Annibynnol. Pan fo'r Pwyllgor yn ystyried mater sy'n ymwneud ag ymddygiad aelod o Gyngor Cymuned, rhaid i o leiaf un aelod o'r Pwyllgor fod yn gynrychiolydd Cyngor Cymuned, ond oni fydd cynrychiolydd Cyngor Cymuned yn bresennol nid yw hynny'n golygu nad oes cworwm ar y Pwyllgor.

(a) Apologies for absence

(b) Disclosures of interest

The Chairman shall ask members of the Standards Committee to disclose the existence and nature of any personal or prejudicial interests which they have in the matter, and to withdraw from consideration of the matter if so required.

(c) Quorum

The Chairman shall confirm that the Standards Committee is quorate²

(ch) Hearing procedure

The Chairman shall confirm that all present know the procedure which the Standards Committee will follow in determining the matter.

(d) Proceeding in the absence of the Member

If the Member is not present at the start of the hearing:

(i) the Chairman shall ask the Monitoring Officer whether the Member has indicated his/her intention not to attend the hearing;

(ii) the Standards Committee shall then consider any reasons which the Member has provided for not attending the hearing and shall decide whether it is satisfied that there is sufficient reason for such failure to attend;

(iii) if the Standards Committee is satisfied with such reasons, it shall adjourn the hearing to another date;

(iv) if the Standards Committee is not satisfied with such reasons, or if the Member has not given any such reasons, the Standards Committee shall decide whether to consider the matter and make a determination in the absence of the Member or to adjourn the hearing to another date.

(dd) Exclusion of Press and Public

The Standards Committee may exclude the press and public from all or part of its consideration of the matter where it appears likely that confidential or exempt information will be disclosed in the course of its consideration.

The Chairman shall ask the Member, the Investigating Officer and the Legal Advisor to the Standards Committee whether they wish to ask the Standards

² A meeting of the Standards Committee is not quorate unless at least three members of the Standards Committee are present for the duration of the meeting. The Chairman must be an Independent member, and at least half of the members of the Committee present must be Independent members. Where the Committee is considering a matter relating to the conduct of a member of a Community Council, at least one member of the Committee must be a Community Council representative, but the Committee is not inquorate by reason of the absence of the Community Council representative.

roi eu rhesymau dros wneud hynny ac yn gofyn am ymatebion gan y lleill, ac yna bydd y Pwyllgor Safonau yn penderfynu a ddylid cau allan y wasg a'r cyhoedd o ran o'r gwrandawriad neu'r cyfan ohono.

Mewn achosion lle nad yw'r Pwyllgor Safonau yn penderfynu cau allan y wasg a'r cyhoedd, bydd y rhaglen ac unrhyw ddogfennau sydd ddim wedi cael eu rhyddhau i'r wasg a'r cyhoedd cyn y cyfarfod yn cael eu rhyddhau wedyn iddynt.

10 **Methiant i gydymffurfio gyda'r Côt Ymddygiad?**

Yna, bydd y Pwyllgor Safonau yn rhoddi sylw i'r mater ynghylch a yw'r Aelod wedi methu cydymffurfio gyda'r Côt Ymddygiad yn y modd a nodir yn adroddiad y Swyddog sy'n Ymchwilio.³

(a) Crynodeb o'r Broses Cyn y Gwrandawriad

Bydd y Cadeirydd yn gofyn i'r Ymgynghorydd Cyfreithiol neu'r Swyddog Cymorth Pwyllgorau gyflwyno'r Adroddiad Crynhoi Cyn-gwrandawriad y Swyddog Monitro, gan ddwyn sylw at unrhyw bwyntiau o wahaniaeth y mae'r Aelod wedi datgan ei fod ef/hi yn anghytuno gydag unrhyw ganfyddiad o ffaith yn adroddiad y Swyddog sy'n Ymchwilio. Yna, bydd y Cadeirydd yn gofyn i'r Aelod gadarnhau bod hwn yn grynodeb cywir o'r materion, i gadarnhau ei fod ef/hi yn parhau i fod o'r un farn ag yr oedd yn y crynodeb cyn y gwrandawriad a gofyn i'r Aelod nodi unrhyw bwyntiau ychwanegol y mae ef/hi yn anghytuno gyda nhw o ran unrhyw ganfyddiad o ffaith yn adroddiad y Swyddog sy'n Ymchwilio.

- (i) Os yw'r Aelod yn cyfaddef ei fod ef/hi wedi methu cydymffurfio gyda'r Côt Ymddygiad yn y modd a ddisgrifir yn adroddiad y Swyddog Ymchwilio, yna gall y Pwyllgor Safonau gymryd adroddiad y Swyddog Ymchwilio fel y mae a phenderfynu bod yr Aelod wedi methu cydymffurfio gyda'r Côt Ymddygiad yn y modd a ddisgrifir yn adroddiad y Swyddog Ymchwilio a symud ymlaen ar unwaith i ystyried a ddylid cymryd unrhyw gamau mewn perthynas â chamymddygiad yr Aelod.
- (ii) Os yw'r Aelod yn nodi unrhyw bwyntiau ychwanegol o wahaniaeth, bydd y Cadeirydd yn gofyn i'r Aelod egluro pam nad oedd ef/hi wedi nodi'r pwyntiau hyn fel rhan o'r broses cyn y gwrandawriad. Bydd ef/hi wedyn yn gofyn i'r Swyddog Ymchwilio (os ydyw'n bresennol) a yw ef/hi mewn sefyllfa i ddelio gyda'r pwyntiau ychwanegol hynny o

³ Noder bod y ystyriaeth y Pwyllgor Safonau wedi gyfyngu i'r mater, o ran y set o ffeithiau, fel a nodir yn adroddiad y Swyddog Ymchwilio. Mae'n bosibl y gall y Pwyllgor Safonau ganfod bod y ffeithiau hyn yn datgelu y torwyd rhan o'r Côt Ymddygiad ac eithrio'r achos a ganfuwyd gan y Swyddog Ymchwilio (er enghraifft, bod y ffeithiau yn gyfystyr â bwlio yn hytrach na dim ond methiant i drin person gyda pharch). Fodd bynnag, os bydd y Pwyllgor Safonau, yn ystod eu trafodaethau, o'r farn bod y dystiolaeth gerbron yn datgelu achos hollol wahanol o fethiant i gydymffurfio gyda'r Côt Ymddygiad (er enghraifft lle mae'r gwyn yn un o fethiant i drin Swyddog A gyda pharch ond bod y dystiolaeth hefyd yn dangos methiant i drin Swyddog B gyda pharch), ni fydd methiant ychwanegol neu fethiant arall yn ran o faes gwaith y Pwyllgor Safonau. Ar yr adeg honno, ni fydd yr Aelod wedi cael rhybudd o'r ffaith bod y Pwyllgor Safonau yn ystyried methiant ychwanegol neu fethiant arall ac o'r herwydd, byddai'n annheg symud ymlaen i ystyried yr ail fater yn y gwrandawriad i'r methiant honedig cyntaf. Lle mae'r Pwyllgor Safonau o'r farn bod methiant ychwanegol neu fethiant arall o bosibl, methiant gan aelod gwahanol neu fethiant o ran Gôd Ymddygiad awdurdod arall, yna dylent gyfeirio'r ail fater i'r Ombwdsmon Gwasanaethau Cyhoeddus cymru fel honiad newydd.

000190

Committee to exclude the press and public from all or any part of the hearing. If any of them so request, the Chairman shall ask them to put forward reasons for so doing and ask for responses from the others, and the Standards Committee shall then determine whether to exclude the press and public from all or any part of the hearing.

Where the Standards Committee does not resolve to exclude press and public, the agenda and any documents which have been withheld from the press and public in advance of the meeting shall then be made available to the press and public.

10 Failure to Comply with the Code of Conduct?

The Standards Committee will then address the issue of whether the Member failed to comply with the Code of Conduct in the manner set out in the Investigating Officer's report.³

(a) The Pre-Hearing Process Summary

The Chairman will ask the Legal Advisor or the Committee Support Officer to present the Monitoring Officer's Pre-Hearing Summary Report, highlighting any points of difference in respect of which the Member has stated that he/she disagrees with any finding of fact in the Investigating Officer's report. The Chairman will then ask the Member to confirm that this is an accurate summary of the issues, to confirm that he/she maintains the position as set out in the pre-hearing summary, and ask the Member to identify any additional points upon which he/she disagrees with any finding of fact in the Investigating Officer's report.

- (i)** If the Member admits that he/she has failed to comply with the Code of Conduct in the manner described in the Investigating Officer's report, the Standards Committee may then take the Investigating Officer's report as read and make a determination that the Member has failed to comply with the Code of Conduct in the manner described in the Investigating Officer's report and proceed directly to consider whether any action should be taken in respect of the Member's misconduct.
- (ii)** If the Member identifies additional points of difference, the Chairman shall ask the Member to explain why he/she did not identify these points as part of the pre-hearing process. He/she shall then ask the Investigating Officer

³ Note that the Standards Committee's consideration is limited to the matter, in terms of the set of facts, as set out in the Investigating Officer's report. The Standards Committee may find that these facts disclose a breach of a part of the Code of Conduct other than that found by the Investigating Officer (for example that the facts constituted bullying rather than just a failure to treat with respect). However, if, in the course of their consideration, the Standards Committee apprehend that the evidence before them reveals an entirely different failure to comply with the Code of Conduct (for example where the complaint is of failure to treat Officer A with respect, but the evidence also indicates a failure to treat Officer B with respect), such a possible additional or alternative failure will not be within the remit of the Standards Committee. At that stage, the member will not have had notice of the Standards Committee's consideration of the possible additional or alternative failure and that it would therefore be unfair to proceed to consider that second matter at the hearing into the first alleged failure. Where the Standards Committee do apprehend a possible additional or alternative failure, a failure by a different member, or a failure in respect of the code of conduct of another authority, they should refer the second matter to the PSOW as a new allegation.

000191

wahaniaeth yn uniongyrchol neu drwy unrhyw dystion sy'n bresennol neu y gellir trefnu yn gyfleus iddynt fod yn bresennol yn y gwrandawriad. Mewn achosion lle nad yw'r Pwyllgor Safonau yn fodlon gyda rhesymau'r Aelod am fethu nodi pob pwynt ychwanegol o wahaniaeth fel rhan o'r broses cyn y gwrandawriad, gall benderfynu parhau gyda'r gwrandawriad ond heb ganiatáu i'r Aelod herio cywirdeb y canfyddiadau ffeithiol hynny a nodir yn adroddiad y Swyddog Ymchwilio ond na wnaeth Aelod nodi pwynt o wahaniaeth yn eu cylch fel rhan o'r broses cyn y gwrandawriad neu gall benderfynu gohirio'r gwrandawriad i ganiatáu i'r Swyddog Ymchwilio ac/neu unrhyw dystion ychwanegol fynychu'r gwrandawriad.

(b) Cyflwyno adroddiad y Swyddog Ymchwilio

- (i) Os yw'r Swyddog Ymchwilio yn bresennol, bydd y Cadeirydd yn gofyn i'r Swyddog Ymchwilio gyflwyno ei adroddiad/ei hadroddiad gyda sylw arbennig i unrhyw bwyntiau o wahaniaeth a nodwyd gan yr Aelod a pham fod ef/hi, ar sail ei g(ch)anfyddiadau ffeithiol ef/hi, o'r farn bod yr Aelod wedi methu â chydymffurfio gyda'r Côd Ymddygiad. Gall y Swyddog Ymchwilio alw tystion fel sy'n angenrheidiol i drafod unrhyw bwyntiau o wahaniaeth.
- (ii) Onid yw'r Swyddog Ymchwilio yn bresennol, ni fydd y Pwyllgor Safonau ond yn cynnal gwrandawriad os ydyw'n fodlon nad oes unrhyw bwyntiau sylweddol o wahaniaeth neu fod modd datrys yn foddhaol unrhyw bwyntiau o wahaniaeth yn absenoldeb y Swyddog Ymchwilio. Yn absenoldeb y Swyddog Ymchwilio, gall y Pwyllgor Safonau benderfynu, ar gais y Swyddog Monitro, pa dystion, os o gwbl i'w galw. Mewn achos lle caiff tystion o'r fath eu galw, bydd y Cadeirydd yn dwyn sylw'r tystion at unrhyw ran berthnasol o adroddiad y Swyddog Ymchwilio ac yn gofyn i'r tyst gadarnhau neu gywiro'r adroddiad a darparu unrhyw dystiolaeth berthnasol.
- (iii) Ni chaniateir unrhyw groesholi ond wedi cyflwyno adroddiad y Swyddog Ymchwilio ac/neu wedi derbyn tystiolaeth pob tyst, bydd y Cadeirydd yn gofyn i'r Aelod a oes unrhyw faterion y dylai'r Pwyllgor Safonau mofyn sylwadau gan y Swyddog Ymchwilio neu'r tyst yn eu cylch ac yna gall Aelodau'r Pwyllgor Safonau ofyn cwestiynau i'r Swyddog Ymchwilio neu'r tyst.

(c) Ymateb yr Aelod

- (i) Bydd y Cadeirydd wedyn yn gwahodd yr Aelod i ymateb i adroddiad y Swyddog Ymchwilio a galw unrhyw dystion fel sy'n angenrheidiol i roi sylw i unrhyw bwyntiau o wahaniaeth.
 - (A) Gall yr Aelod drefnu i'w gynrychiolydd/chynrychiolydd wneud cyflwyniad ar ei ran/ei rhan ac/neu i gyflwyno'r Aelod ac unrhyw dystion ar ei ran/ei rhan.
 - (B) Nid oes rhaid i'r Aelod roi tystiolaeth neu ateb unrhyw gwestiynau ond gall y Pwyllgor Safonau yn rhesymol ddod i gasgliadau o unrhyw fethiant ar ei ran/rhan i roi tystiolaeth neu i ateb unrhyw gwestiwn.

000192

(if present) whether he/she is in a position to deal with those additional points of difference directly or through any witnesses who are in attendance or whose attendance at the hearing can conveniently be arranged. Where the Standards Committee is not satisfied with the Member's reasons for failing to identify each additional point of difference as part of the pre-hearing process, it may decide that it will continue the hearing but without allowing the Member to challenge the veracity of those findings of fact which are set out in the Investigating Officer's report but in respect of which the Member did not identify a point of difference as part of the pre-hearing process, or it may decide to adjourn the hearing to allow the Investigating Officer and/or any additional witnesses to attend the hearing.

(b) Presenting the Investigating Officer's report

- (i) If the Investigating Officer is present, the Chairman will then ask the Investigating Officer to present his/her report, having particular regard to any points of difference identified by the Member and why he/she concluded, on the basis of his/her findings of fact, that the Member had failed to comply with the Code of Conduct. The Investigating Officer may call witnesses as necessary to address any points of difference.
- (ii) If the Investigating Officer is not present, the Standards Committee shall only conduct a hearing if they are satisfied that there are no substantial points of difference or that any points of difference can be satisfactorily resolved in the absence of the Investigating Officer. In the absence of the Investigating Officer, the Standards Committee shall determine on the advice of the Monitoring Officer which witnesses, if any, to call. Where such witnesses are called, the Chairman shall draw the witnesses' attention to any relevant section of the Investigating Officer's report and ask the witness to confirm or correct the report and to provide any relevant evidence.
- (iii) No cross-examination shall be permitted but, at the conclusion of the Investigating Officer's report and/or of the evidence of each witness, the Chairman shall ask the Member if there are any matters upon which the Standards Committee should seek the representations of the Investigating Officer or the witness, and then the members of the Standards Committee may address questions to the Investigating Officer or the witness.

(c) The Member's response

- (i) The Chairman shall then invite the Member to respond to the Investigating Officer's report and to call any witnesses as necessary to address any points of difference.
 - (A) The Member may arrange for his representative to make submission on his behalf, and/or to introduce the Member and any witnesses on his behalf;
 - (B) The Member does not have to give evidence or to answer any questions, but the Standards Committee may draw reasonable conclusions from any failure on his part to give evidence or to answer any question.
- (ii) No cross-examination shall be permitted but, at the conclusion of the